

Cast Stone

THE TRADITIONAL RANGE



MEXBORO

THE CAST MASTERS

Cast Stone

THE TRADITIONAL RANGE

Mexboro Company History.

For over 30 years Mexboro has been at the forefront of manufacturing high quality architectural cast stone and is now able to offer a wide range of classical cast stone components, which we are proud to present as our Traditional Range.

The versatility appearance and performance of cast stone has led to a huge increase in its popularity.



Cast stone is regularly used in the restoration and refurbishment of historic buildings and churches. It is also used to enhance the aesthetic appeal of modern new build housing, institutional, commercial and public sector developments.

Mexboro is proud to have been associated with the supply of cast stone to many national house builders and has been involved in numerous prestigious developments through out the country and overseas, including those under the direction of English Heritage, the National Trust, PSA and Ministry of Defence.

A recent successfully completed contract saw the supply of £500,000 of cast stone to Berkeley Homes Limited at their prestigious Harrods Village development in Barnes, London.

Manufacture.

Semi-Dry Process.

The Mexboro Traditional Range of cast stone components are manufactured by skilled craftsmen using the semi-dry process and then hand finished to produce a product virtually identical to quarried stone in appearance and texture, but at a fraction of the cost.

High quality and carefully graded limestones and sands are mixed with a cement binder to a earth moist consistency and then mechanically compacted into the mould. The unit is then instantly demoulded and hand finished through traditional methods.

The method of compacting achieves a compression strength in excess of that required by BS 1217: 1997 specification for cast stone.

The use of an integral waterproofer ensures that the product complies with the capillary absorption test of BS 1217: 1997 and that the product weathers in a similar way to natural stone in similar circumstances.

Wetcast Process.

Mexboro also produces structural cast stone utilising the wetcast process which achieves a denser product with a close textured surface finish.

This method allows for larger units to be manufactured and those with often complex reinforcement details. The company's modern factory allows for the production and handling of individual units up to the weight of 10 tons.

The wetcast process uses a comparatively wider range of aggregate sizes in a higher water content mix. The mix is then vibrated within the mould and after its initial cure is demoulded, to be then worked on by the company's skilled finishers. Highly authentic cast stone is achieved by the finishers who remove the laitance (a cement laitance which forms against the mould face normally 0.5-1.0mm thick). Numerous different finishes can be achieved by the method of removing this laitance and Mexboro personnel are experienced in acid etching, abrasive rubbing, grit blasting, retarding, bush hammering and polishing. Mexboro has recently purchased a Jenny Lind machine specifically for polishing.

The units manufactured by the wetcast process will retain their supplied appearance for a longer period and comply with the initial surface absorption test for weathering as specified in BS 1217: 1997.





Pattern and Mould Making.

Mexboro operates its own pattern and mould making shop and can accommodate the most intricate shapes and designs. This enables the company to undertake specialist bespoke projects to clients individual requirements which are often prohibitively expensive to achieve in natural stone.

Colours and Finishes.

Manufactured in a range of mellow standard colours using a variety of natural crushed aggregates, the Traditional Range of cast stone components will harmonise well with most building fabrics, whether traditional or new build. The Mexboro standard colour range includes: Portland, Bathstone, Hamstone, Red Sandstone, Yorkstone and Cotswold stone.

With precise pigment control virtually any colour, shade or hue can be achieved. Please contact our sales office for information or samples.

Whilst every effort is made to ensure uniformity in colour, these products are manufactured from natural materials and occasional variations may occur as they do in natural quarried stone.

Quality Control.

Mexboro cast stone units are manufactured in accordance with BS 1217: 1997

Regular internal and external quality control tests are carried out and Mexboro operates its own NAMAS calibrated testing equipment as well as undertaking external independent tests.

- The aggregates used conform to the British Standard BS 882: 1992
- The cement binder used conform to the British Standard BS 12: 1996
- The oxide pigments used conform to the British Standard BS 1014: 1975
- Any admixture applied would conform to the British Standard BS 5075

Structural.

The Traditional Range of cast stone components are decorative and reinforcement is included within the product for handling purposes only.

Certain components within the range can be made structural upon the clients own professional engineers advice and we recommend that our sales office should be contacted for further information in this instance.

Standard heads for windows and doors with a section of 100 x 140 mm or larger are designed to carry a 3 kn uniformly distributed load for a clear span up to 1 metre however attention should be paid to avoid any shock loading during installation. We recommend that all heads are used in conjunction with a suitable load bearing lintel (Catnic or similar). Steel support lintels are normally used below the decorative head however there are occasions when the structural steel is inserted over the head and the head itself becomes self supporting.

Design Detailing.

If required Mexboro can arrange for the full structural design and detailing of units along with their associated fixings. *Please contact our sales office for further information.*

Fixings.

The Traditional Range of window and door surrounds are easily incorporated into the envelope of the building using readily available cramps and dowels.

Stainless steel dowels should be used for restraint fixing of head or cills to jambs or e.g. jamb to jamb when supplied in more than one section.

A wide range of fixings are available on the market, with some being more suitable than others in certain applications. *Please contact our sales office for further information.*



Site Fixing.

Although cast stone is associated with traditional masonry methods of fixing, Mexboro can provide where necessary advice and/or details of associated companies who will undertake the site fixing requirements of the project. *Please contact our sales office for further information.*

Mortar Recommendations.

Refer to BS 5628 part 3 :1985

Experience suggests that mortars should not be stronger than required for design purposes. Mortars containing lime give a better bond and resistance to rain penetration. Lime mortars also have the added benefit of self healing small cracks over time.

The UKCSA technical manual offers good advice on mortars and refers to the following technical information:

Exposure Condition	Mortar Designation	Mortar Mixes		
		Cement: Lime: Sand	Air-entrained Mixes	
			Masonry Cement: Sand	Cement: Sand & Plasticizer
Severe	[iii]	1 : 1 : 5 to 6	1 : 4 to 5	1 : 5 to 6
Moderate	[iv]	1 : 2 : 8 to 9	1 : 5 to 6	1 : 7 to 8

All proportions by volume

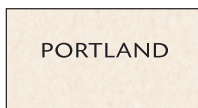
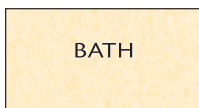

Cast Stone Blocks



ASHLAR BLOCK

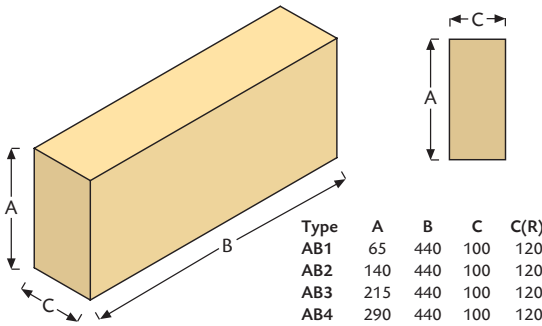

QUOIN STONES

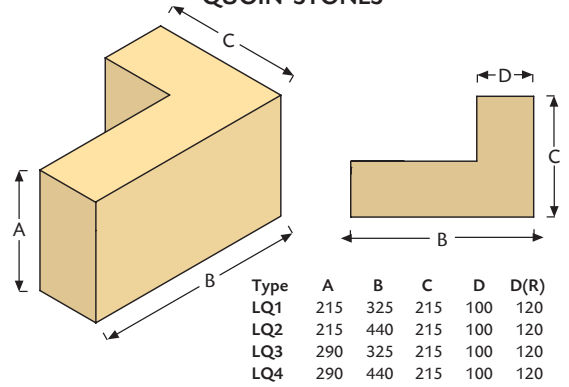

PLINTH BLOCK

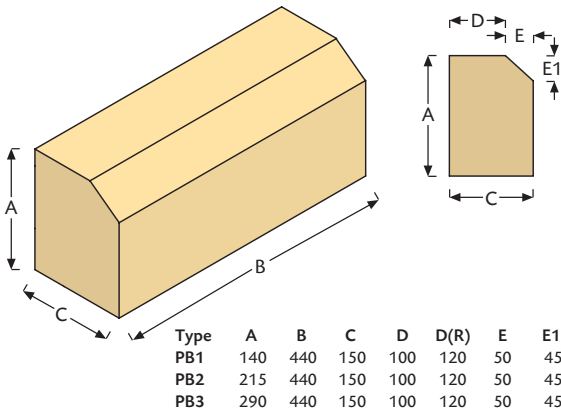

CHAMFERED QUOIN STONES

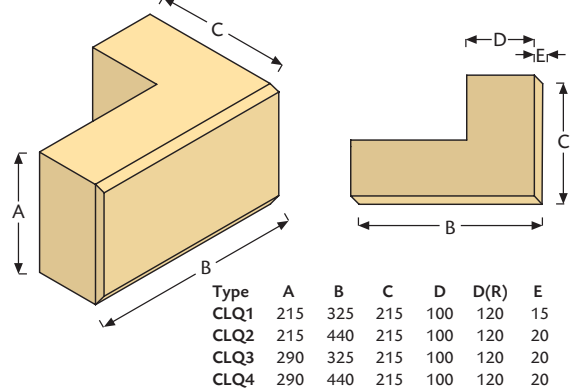

UNDER PLINTH BLOCK

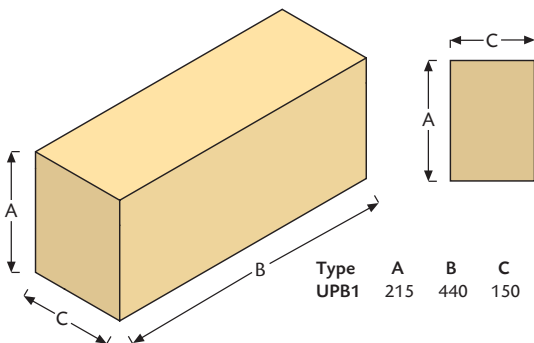

DOOR AND WINDOW JAMB BLOCKS

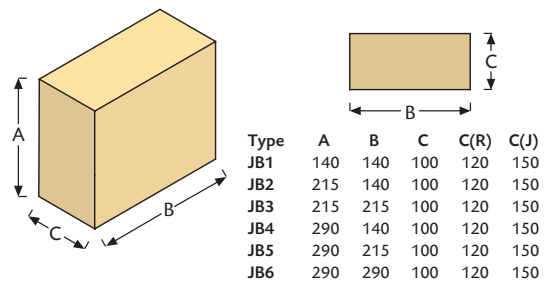

Notes:

1. (R) Denotes additional thickness to accommodate rendered wall.
2. (J) Denotes use in conjunction with standard window surround type WSS
3. Internal and external returns are available.

STRAIGHT HEAD

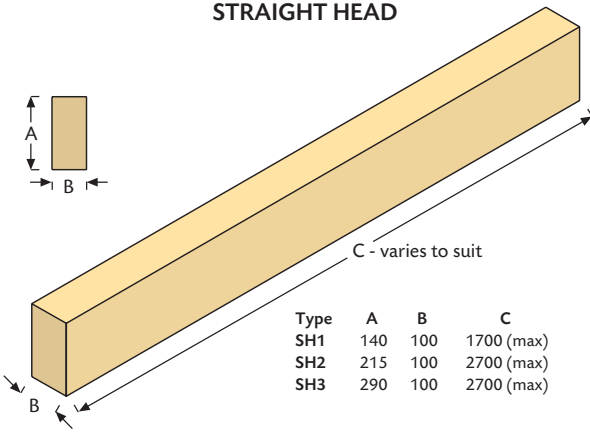

Type	A	B	C
SH1	140	100	1700 (max)
SH2	215	100	2700 (max)
SH3	290	100	2700 (max)

KEYSTONE HEAD

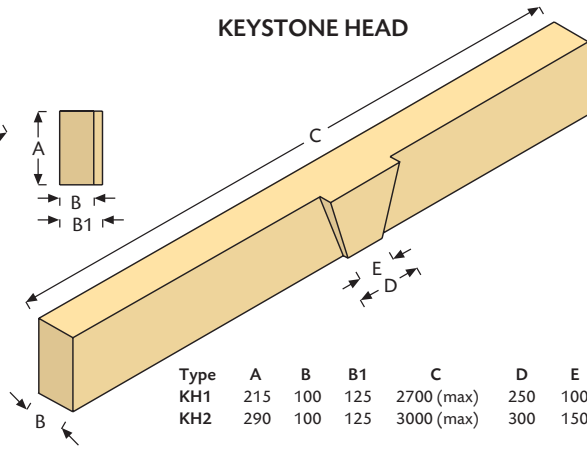

Type	A	B	B1	C	D	E
KH1	215	100	125	2700 (max)	250	100
KH2	290	100	125	3000 (max)	300	150

SPLAYED HEAD

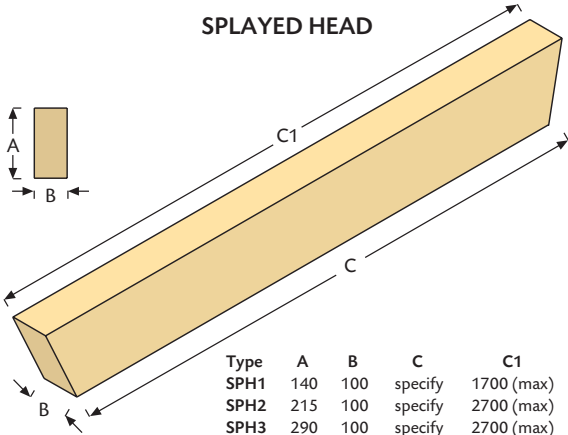

Type	A	B	C	C1
SPH1	140	100	specify	1700 (max)
SPH2	215	100	specify	2700 (max)
SPH3	290	100	specify	2700 (max)

PROJECTING KEYSTONE HEAD

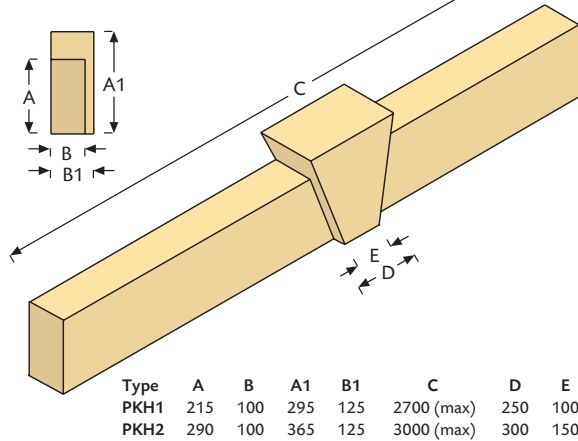

Type	A	B	A1	B1	C	D	E
PKH1	215	100	295	125	2700 (max)	250	100
PKH2	290	100	365	125	3000 (max)	300	150

CHAMFERED HEAD

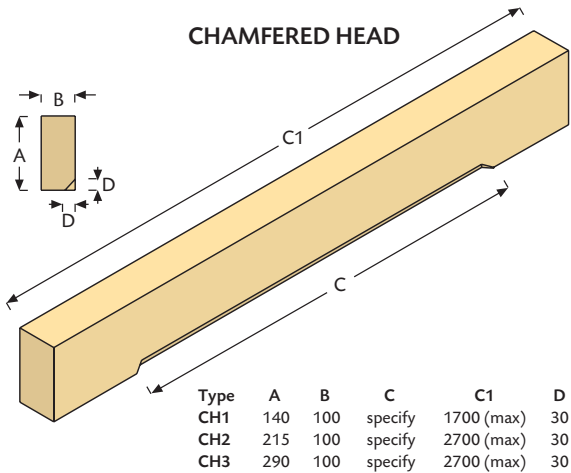

Type	A	B	C	C1	D
CH1	140	100	specify	1700 (max)	30
CH2	215	100	specify	2700 (max)	30
CH3	290	100	specify	2700 (max)	30

Note:

- Decorative head units are to be used in conjunction with a load bearing lintel, catnic or similar.
- Units can be supplied in sections where lengths required are greater than those specified.



KEYSTONE

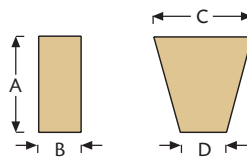

Type	A	B	C	D
K1	215	128	260	140
K2	290	128	300	140

DECORATIVE KEYSTONE

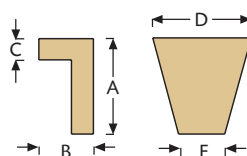

Type	A	B	C	D	E
DK1	215	165	65	260	140
DK2	290	165	65	300	140



Cill Units

CILL UNITS - 150mm wide

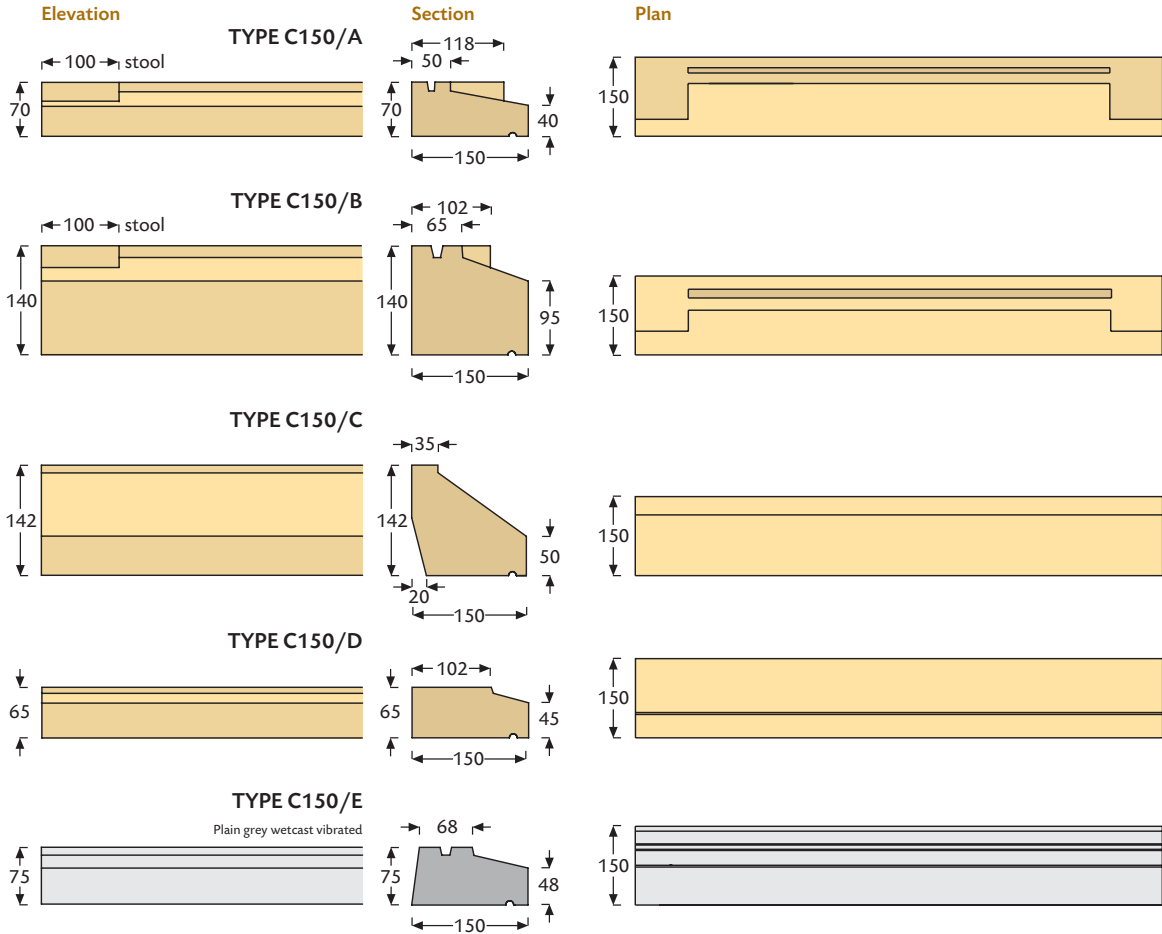

CILL UNITS - 175mm wide

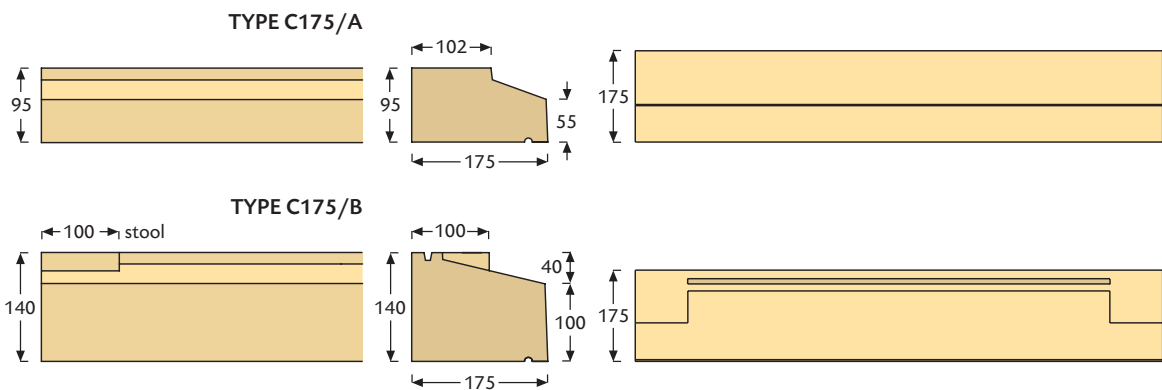

CILL BRACKETS

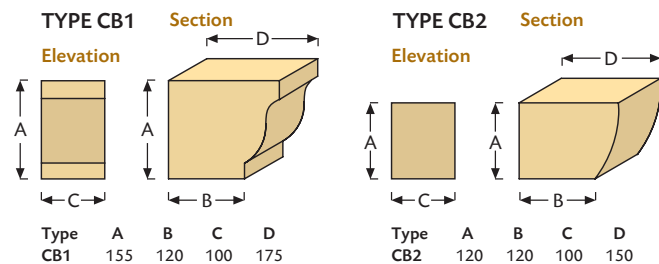

Note: 1. Cills can be supplied as straight sections without stooled ends - please specify.
 2. Cills can be supplied with different width stooled ends - please specify.

CILL UNITS - 200mm wide

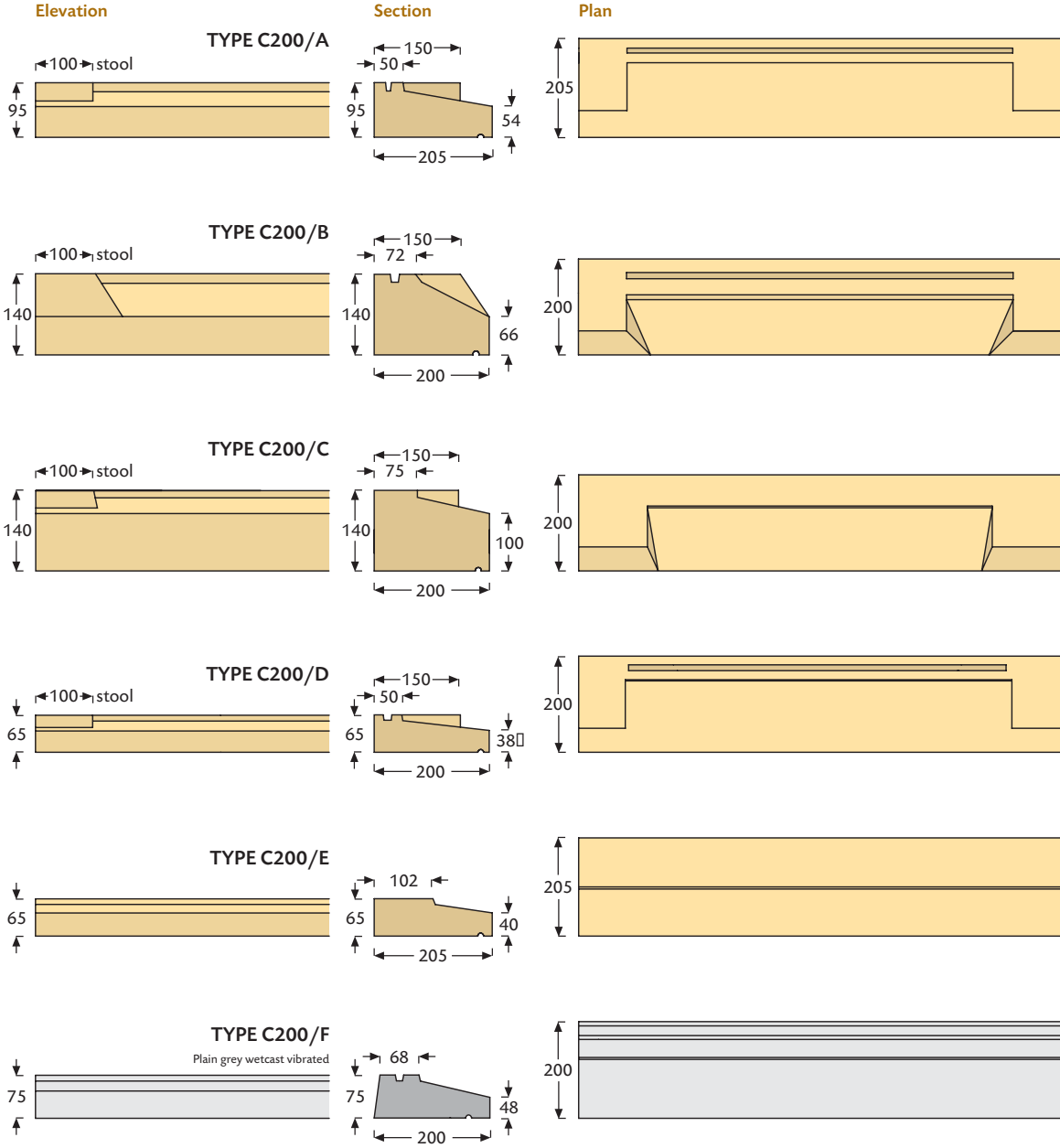

CILL UNITS - 215mm wide

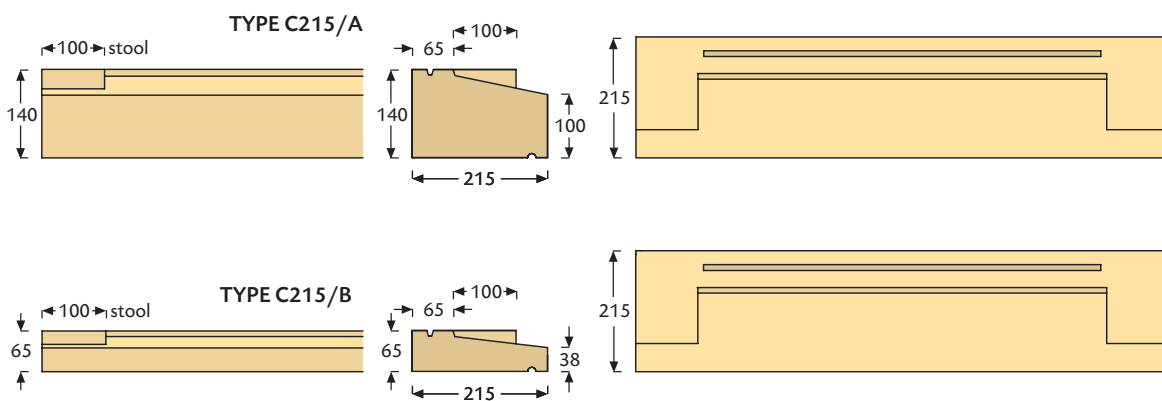

Note: 1. Cills can be supplied as straight sections without stooped ends - please specify.
2. Cills can be supplied with different width stooped ends - please specify.

Window Surrounds

WINDOW SURROUND TYPE WS1

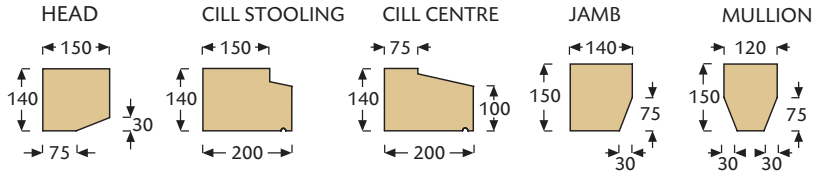

Width W = 490/630/915 · Height H = please specify.

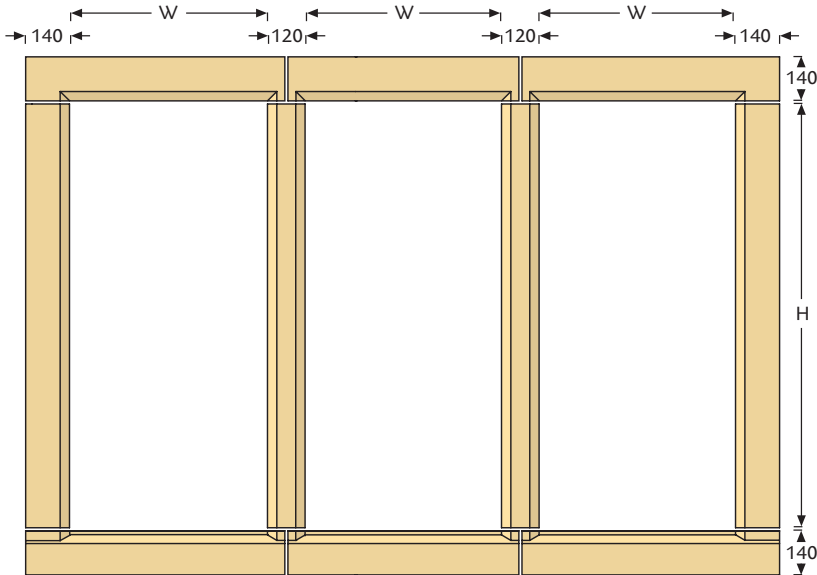

Note: Heads to be used in conjunction with load bearing lintel, Catnic or similar.

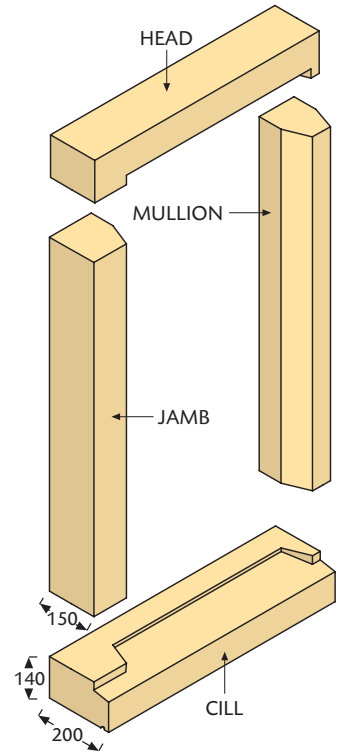

WINDOW SURROUND TYPE WS2

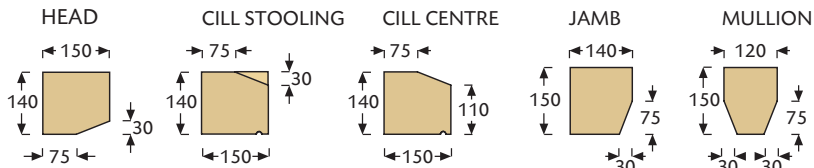

Width W = 490/630/915 · Height H = please specify.

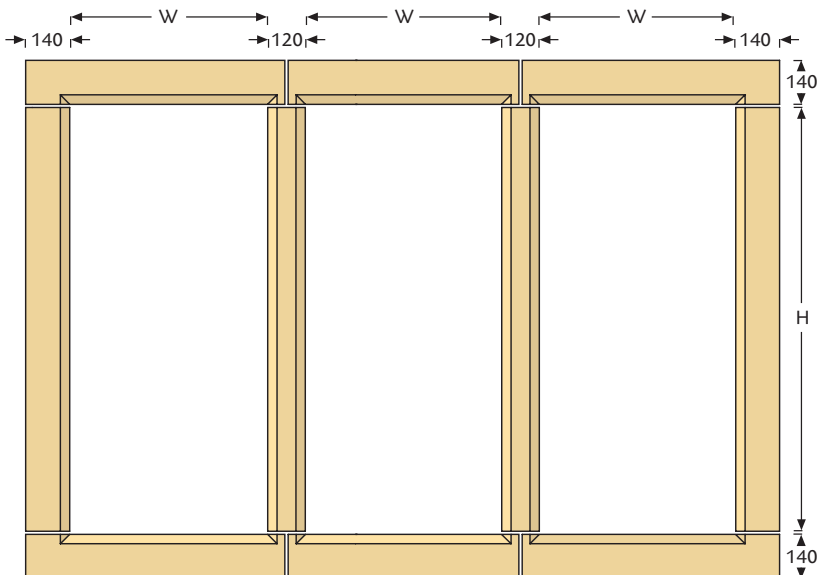

Note: Heads to be used in conjunction with load bearing lintel, Catnic or similar.

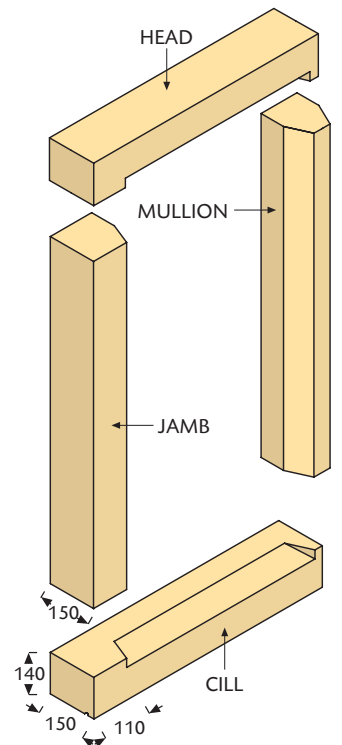

WINDOW SURROUND TYPE WS3

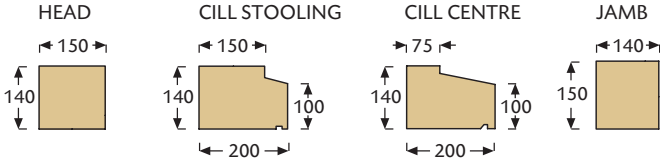

Width W and Height H = please specify.

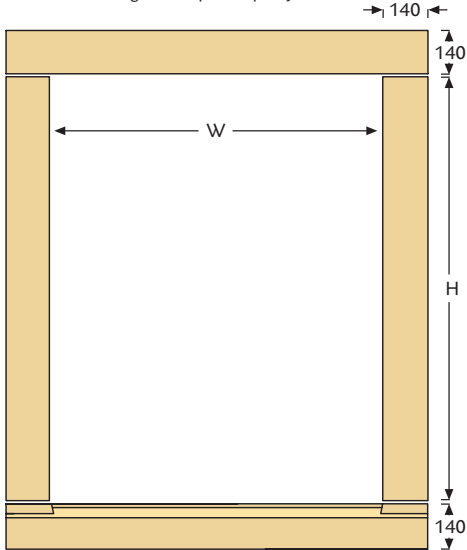

Note: Heads to be used in conjunction with load bearing lintel, Catnic or similar.

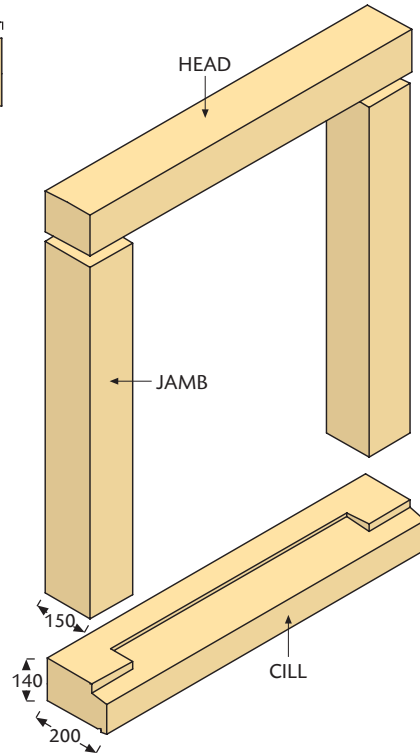

WINDOW SURROUND TYPE WS4

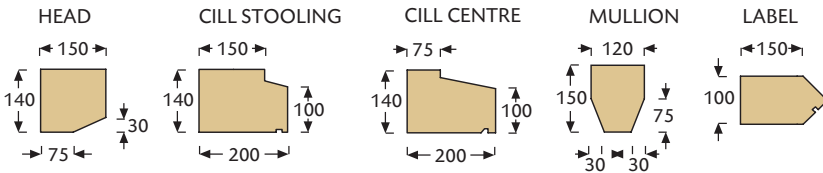

Width W = 490/630/915 · Height H = please specify (to suit coursing).

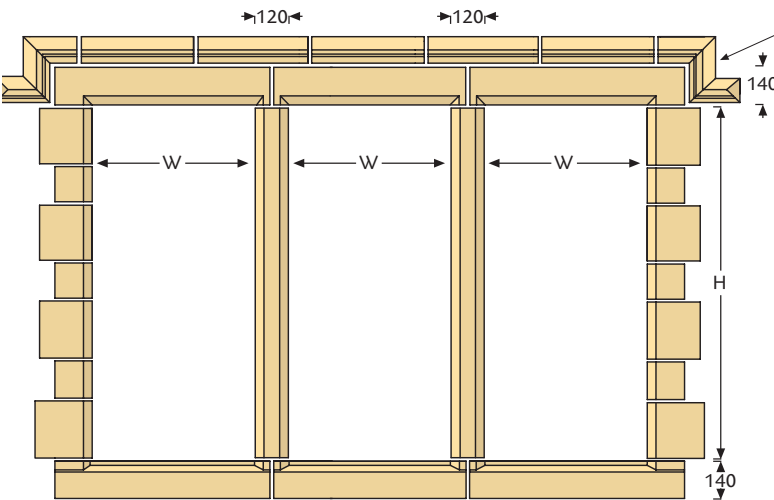

Note: Heads to be used in conjunction with load bearing lintel, Catnic or similar.

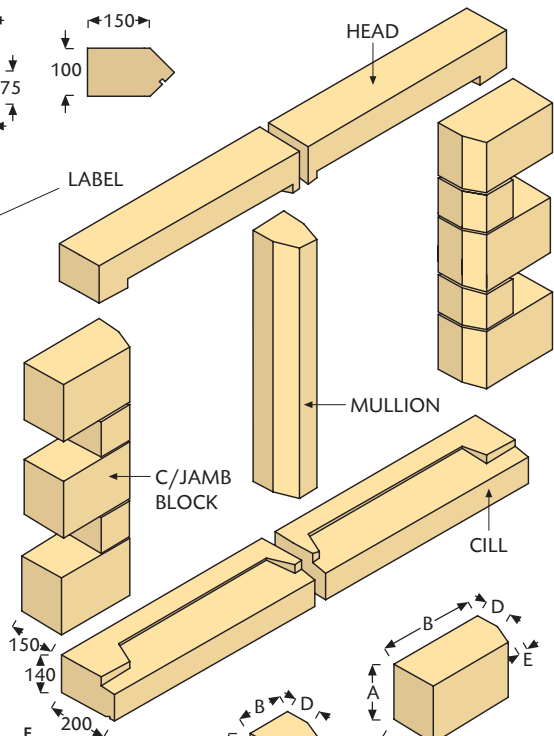

CHAMFERED JAMB BLOCKS

Type	A	B	C	D	E	Type	A	B	C	D	E
CJB1	140	140	150	75	30	CJB5	290	140	150	75	30
CJB2	140	215	150	75	30	CJB6	290	215	150	75	30
CJB3	215	140	150	75	30	CJB7	290	290	150	75	30
CJB4	215	215	150	75	30						

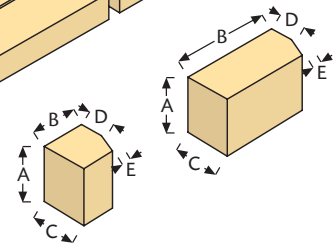

WINDOW SURROUND TYPE WS5

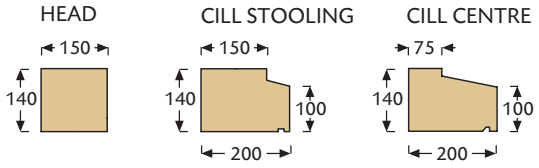

Width W = please specify · Height H = please specify (to suit coursing).

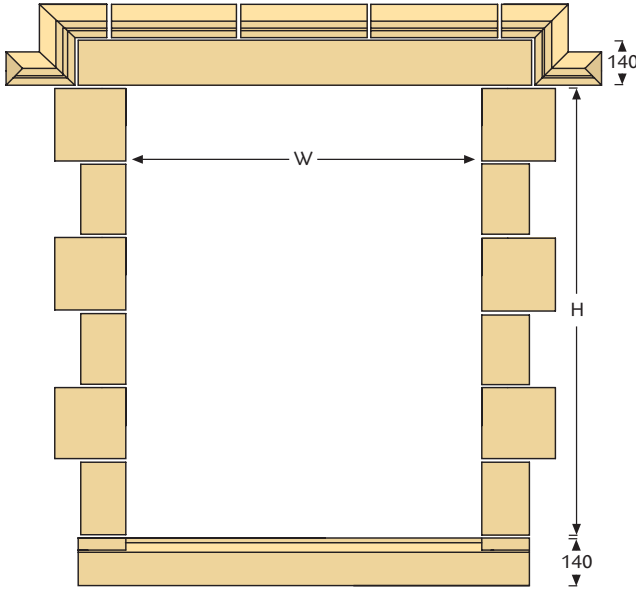

Notes:

1. Heads to be used in conjunction with load bearing lintel, Catnic or similar.
2. Alternative 215 or 290mm heads also available with or without Keystone.

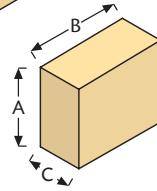
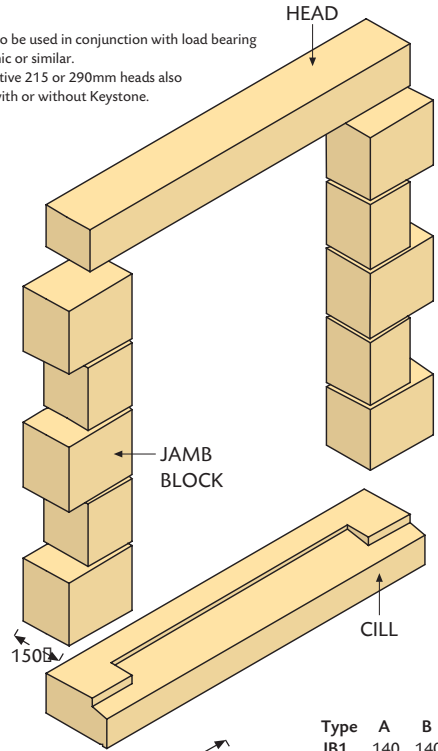

Type	A	B	C
JB1	140	140	150
JB2	140	215	150
JB3	215	140	150
JB4	215	215	150
JB5	290	140	150
JB6	290	215	150
JB7	290	290	150

Label Units

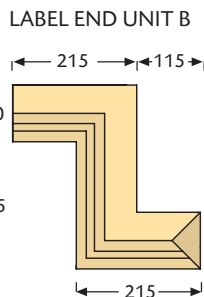
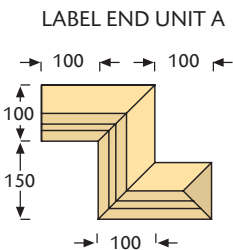
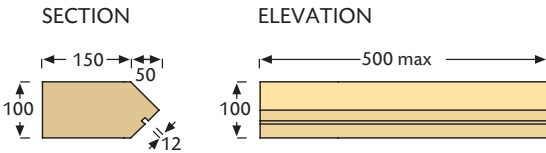
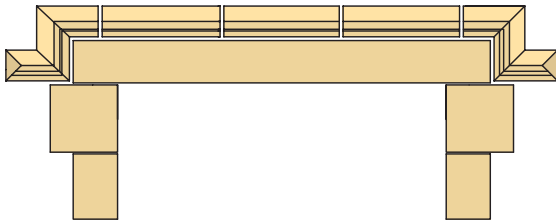

Note:
Label Unit A used in conjunction with 140mm head.
Label Unit B used in conjunction with 215mm head.



TYPE CCW1/Ø 600

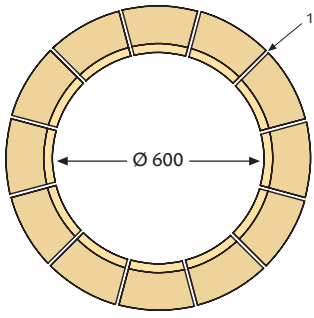

TYPE CKCW1/Ø 600

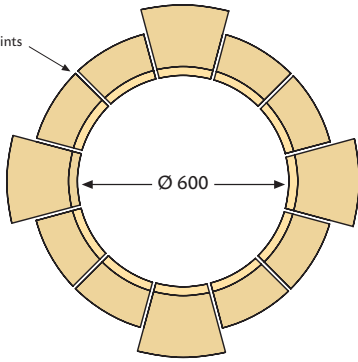

TYPE CCW2/Ø 915

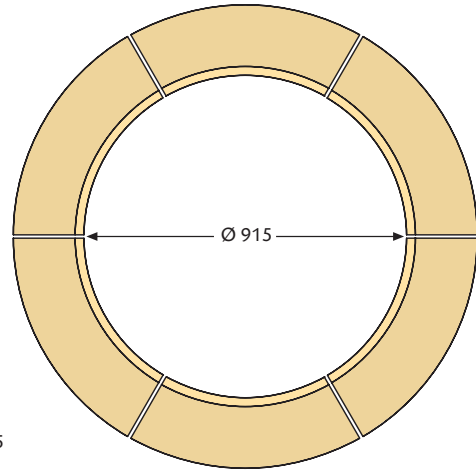

Section enlarged
TYPE CCW1/Ø 600

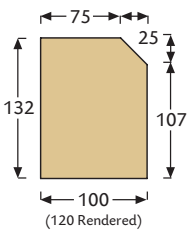

Section enlarged
TYPE CKCW1/Ø 600

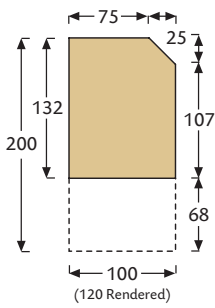

Section enlarged
TYPE CCW2/Ø 915

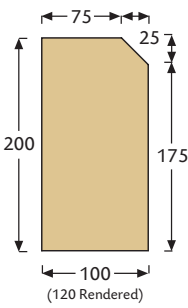

Arched Window Surrounds

TYPE AWS 1/1200

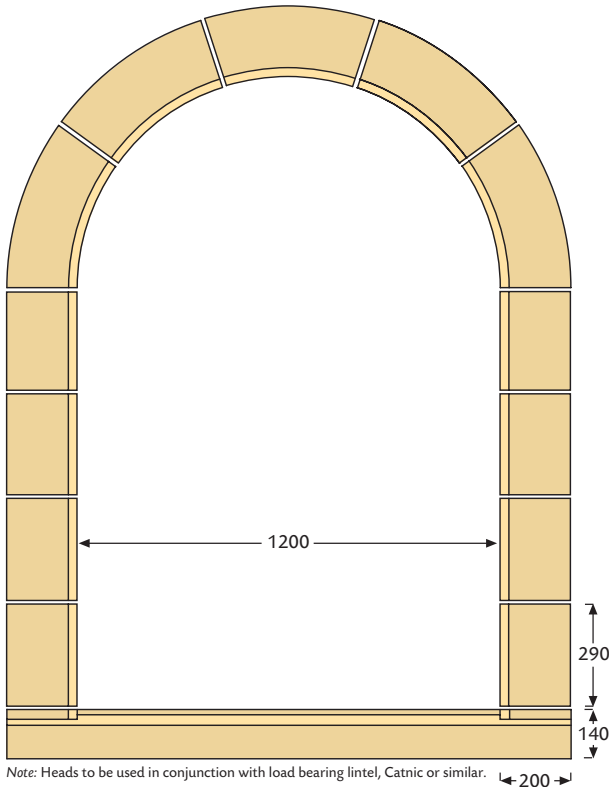

TYPE AWS 2/915

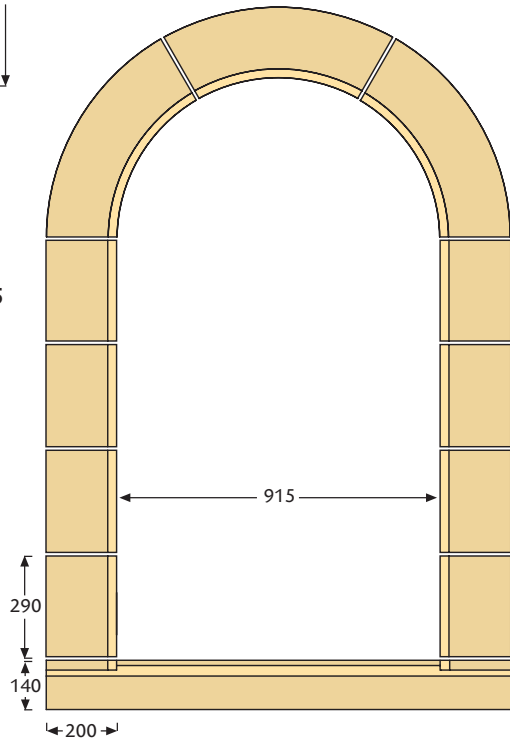

AWS1 / AWS2
Jamb Block
Section enlarged.

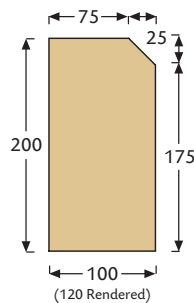

Type C150/B
Cill Section enlarged
with 200mm chamfered
stooling.

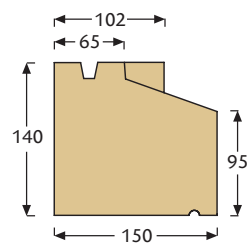

Note: Heads to be used in conjunction with load bearing lintel, Catnic or similar.



DOOR SURROUND CHAMFERED TYPE DSC1

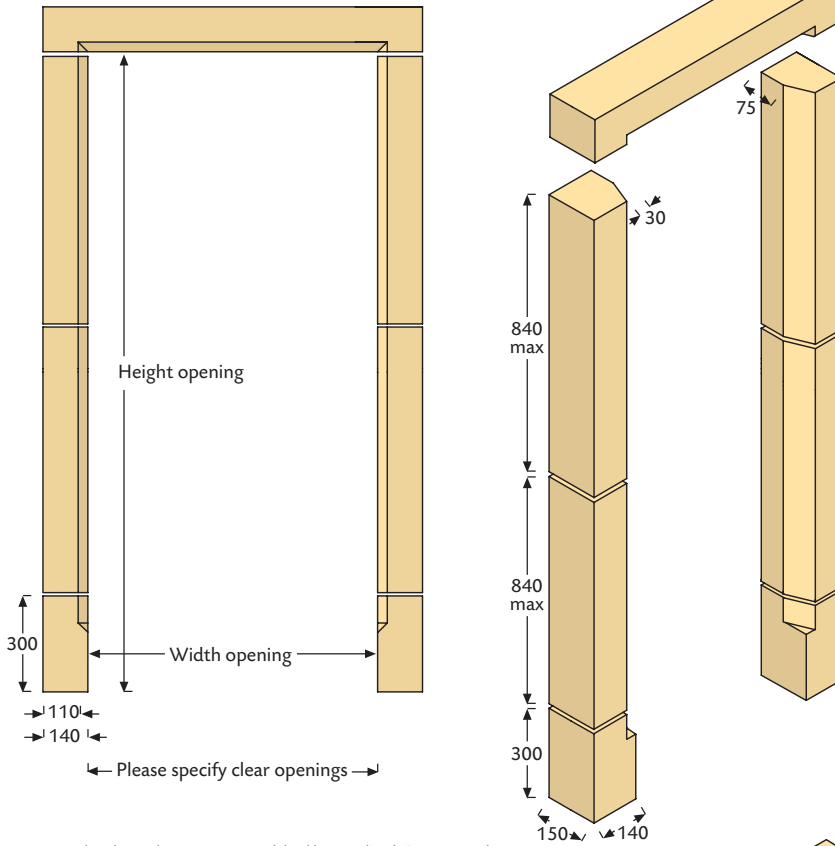

Note: Heads to be used in conjunction with load bearing lintel, Catnic or similar.



Door Surround Chamfered Jamb Blocks

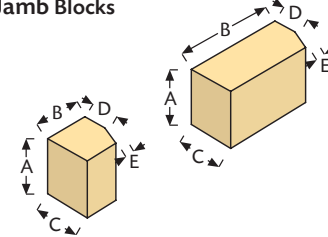

Type	A	B	C	D	E
CJB1	140	140	150	75	30
CJB2	140	215	150	75	30
CJB3	215	140	150	75	30
CJB4	215	215	150	75	30
CJB5	290	140	150	75	30
CJB6	290	215	150	75	30
CJB7	290	290	150	75	30

DOOR SURROUND WITH CHAMFER JAMB BLOCKS TYPE DSCJB1

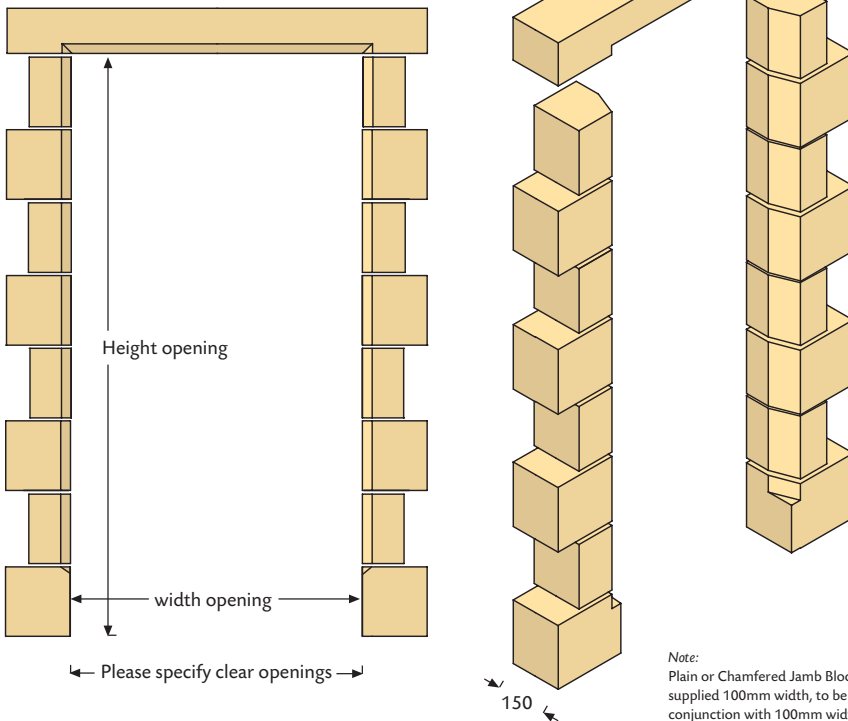

Note: Plain or Chamfered Jamb Blocks can be supplied 100mm width, to be used in conjunction with 100mm width Heads.

Alternative Plain Jamb Blocks

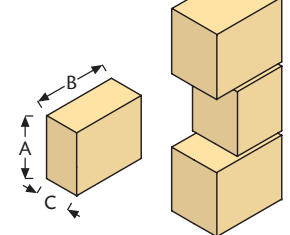

Type	A	B	C
JB1	140	140	150
JB2	140	215	150
JB3	215	140	150
JB4	215	215	150
JB5	290	140	150
JB6	290	215	150
JB7	290	290	150

PORCH ENTRANCE SURROUND TYPES PES1/1365 and PES2/1800

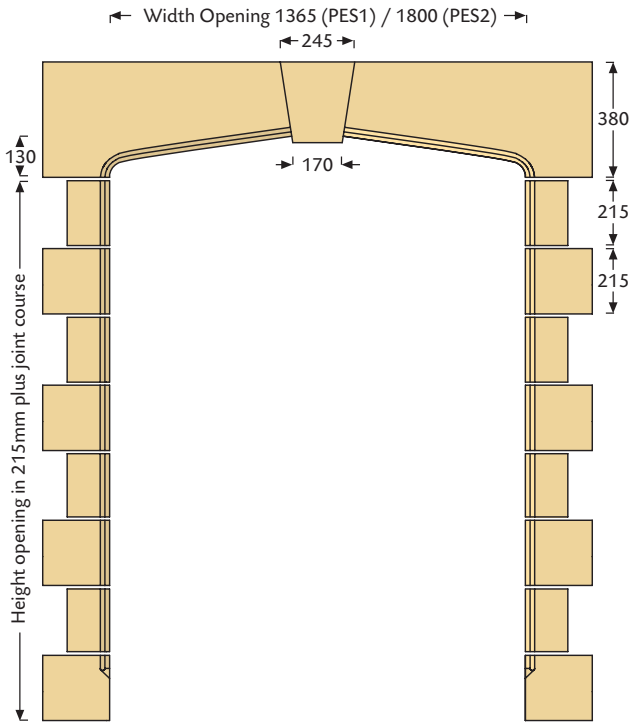

Section through
Porch Lintel.

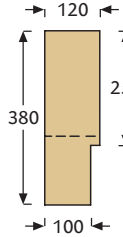

Section through
Porch Jamb Block.

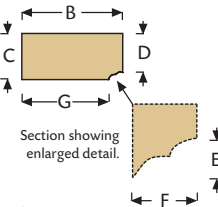

Porch Entrance
Jamb Block.

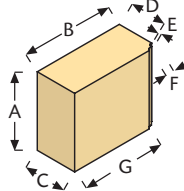

Type	A	B	C	D	E	F	G
PEJB1	215	90	100	85	15	30	60
PEJB2	215	155	100	85	15	30	125
PEJB3	215	220	100	85	15	30	190

DOUBLE PORCH ENTRANCE SURROUND

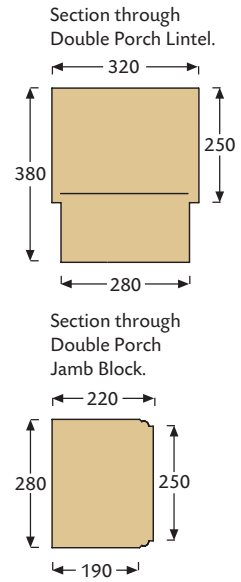

PORCH ENTRANCE SURROUND TYPE PES3

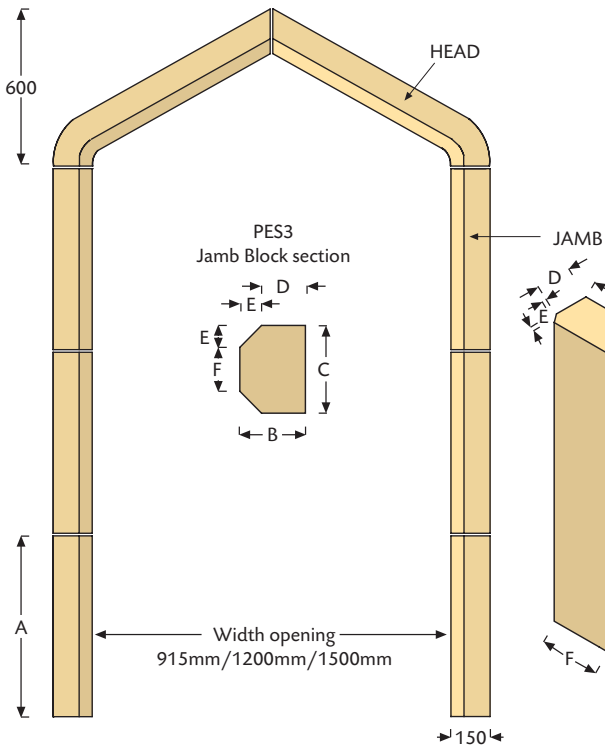

Type	A	B	C	D	E	F
PES3 J/H1	1000 max	150	200	100	50	100
PES3 J/H2	1000 max	150	250	100	50	150
PES3 J/H3	1000 max	150	280	100	50	180

PORCH ENTRANCE SURROUND TYPE PES4

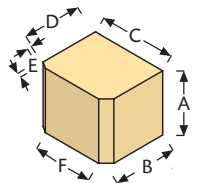
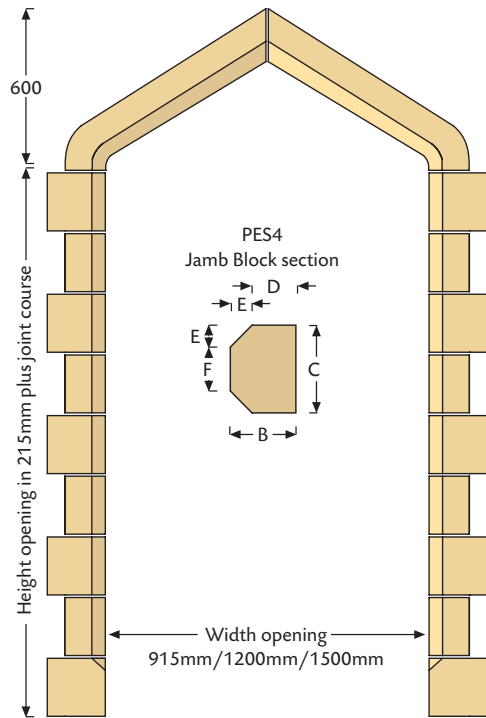

Type	A	B	C	D	E	F
PES4 JB1	215	150	200	100	50	100
PES4 JB2	215	150	250	100	50	150
PES4 JB3	215	150	280	100	50	180
PES4 JB4	215	215	200	165	50	100
PES4 JB5	215	215	250	165	50	150
PES4 JB6	215	215	280	165	50	180



String Courses

SINGLE CHAMFER STRING COURSE

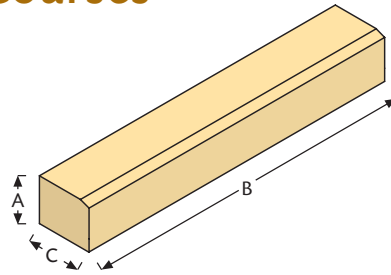
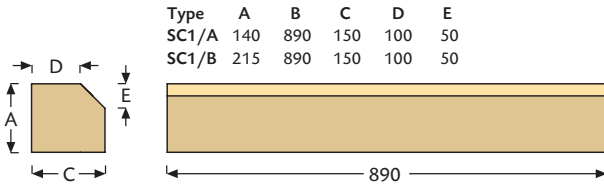

DOUBLE CHAMFER STRING COURSE

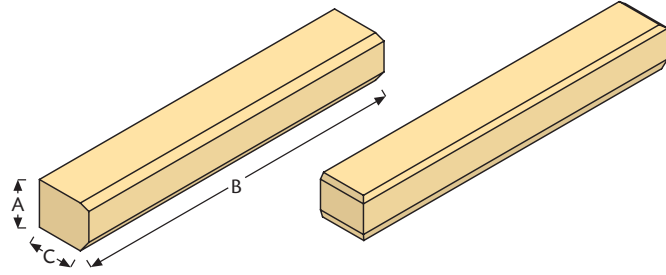
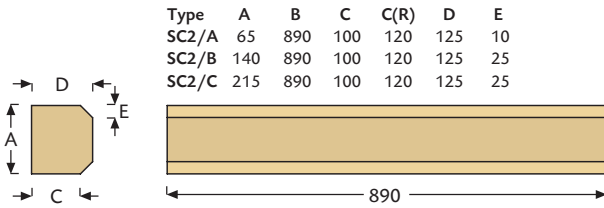

CILL BAND COURSE

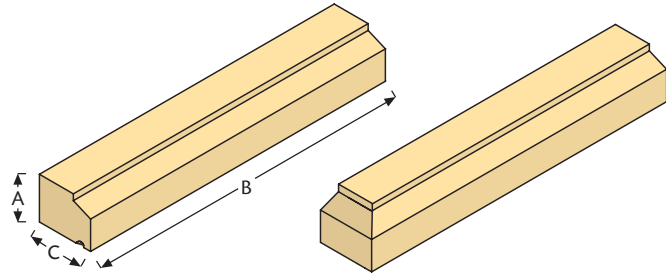
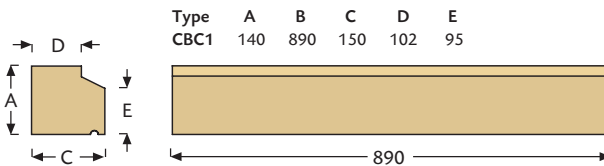

Note: Cill Band Course can be used in conjunction with Cill type C150/B.

FEATURE STRING COURSE FSC1

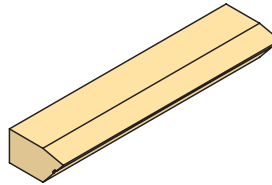

FEATURE STRING COURSE FSC2

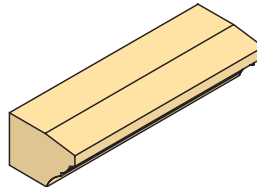
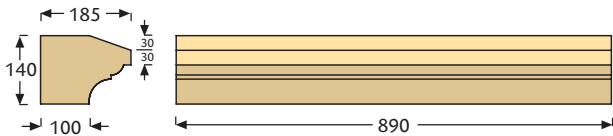

FEATURE STRING COURSE FSC3

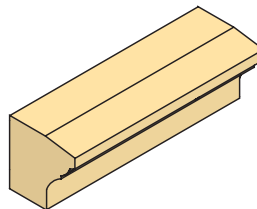
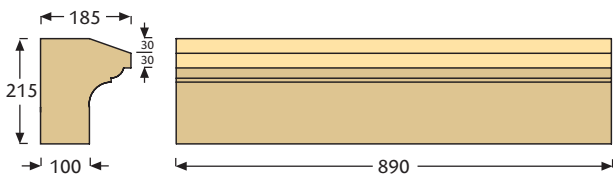

FEATURE STRING COURSE FSC4

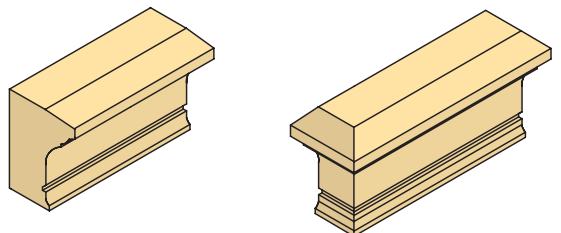
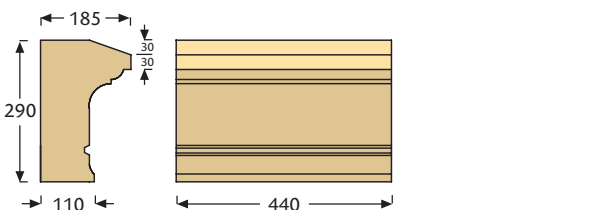

Note: Internal and External Return Ends are available for all String and Cill Band Courses.

ONCE WEATHERED

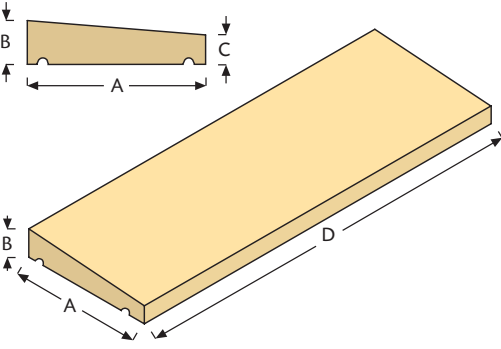

Type	A	B	C	D	Type	A	B	C	D
OWC1	178	75	50	915	OWC5	400	75	50	915
OWC2	228	75	50	915	OWC6	455	75	50	600
OWC3	305	75	50	915	OWC7	500	100	75	600
OWC4	355	75	50	915	OWC8	600	100	75	500

Once Weathered Internal Corner Unit
Ref: OWIC

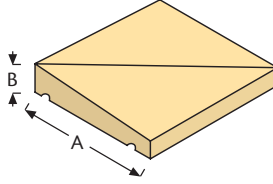

Once Weathered External Corner Unit
Ref: OWEC

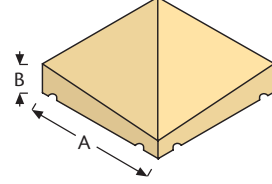

TWICE WEATHERED

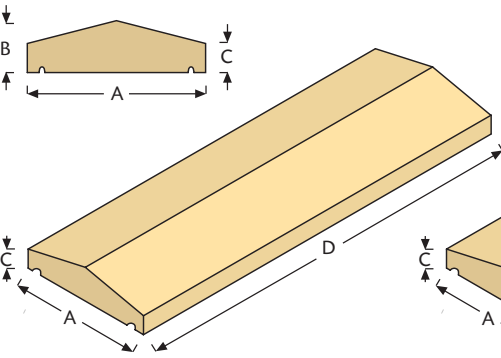

Type	A	B	C	D	Type	A	B	C	D
TWC1	178	72	50	915	TWC5	400	90	50	915
TWC2	228	79	50	915	TWC6	455	90	50	600
TWC3	305	90	50	915	TWC7	500	110	50	600
TWC4	355	90	50	915	TWC8	600	110	50	500

Twice Weathered - Stop End
Ref: TWCSE

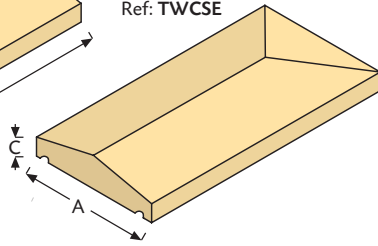

Twice Weathered Corner Return
Ref: TWCRC

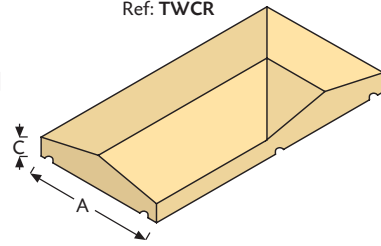

FLAT TOP

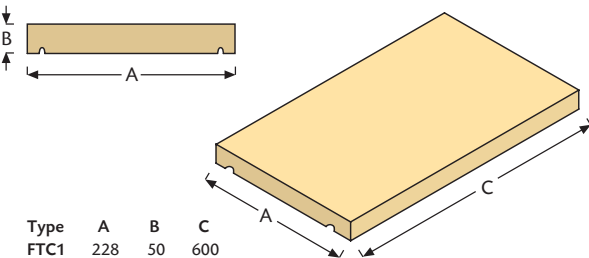

Type	A	B	C
FTC1	228	50	600
FTC2	305	50	600
FTC3	355	50	600
FTC4	400	50	600

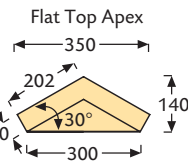

Typical Apex Sections

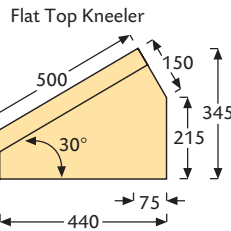
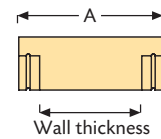

Typical Kneeler Sections

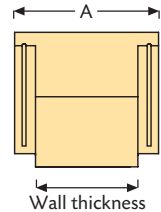

PIER CAPS

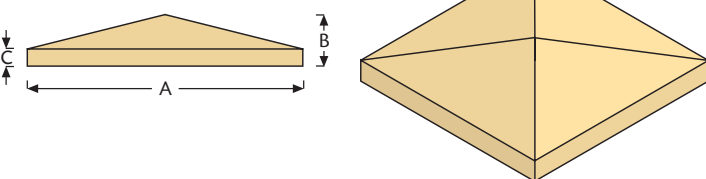

Type	A	B	C	Type	A	B	C
PC1	305	75	45	PC8	530	125	70
PC2	310	75	45	PC9	540	100	55
PC3	380	85	50	PC10	605	125	70
PC4	380	100	55	PC11	615	120	50
PC5	460	100	55	PC12	710	130	50
PC6	460	115	55	PC13	795	175	75
PC7	480	120	60	PC14	800	150	50



Architectural Coping

ARCHITECTURAL COPING

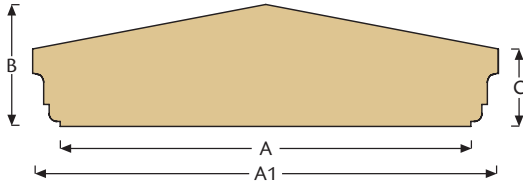

Type	A	A1	B	C	D
AC1	225	275	110	70	915
AC2	310	360	110	70	915
AC3	370	420	110	70	915
AC4	430	480	110	70	915
AC5	470	520	110	70	915
AC6	600	650	110	70	915

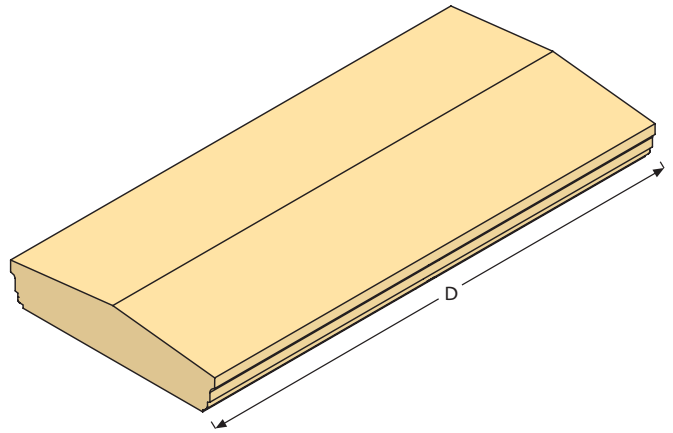

ARCHITECTURAL PIER CAPS

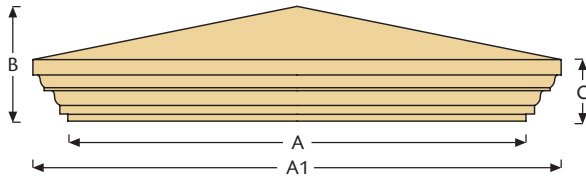

Type	A	A1	B	C
APC1	360	440	110	70
APC2	400	480	130	100
APC3	480	560	150	110
APC4	520	620	175	145
APC5	630	735	175	145
APC6	700	805	175	95
APC7	890	1010	175	125

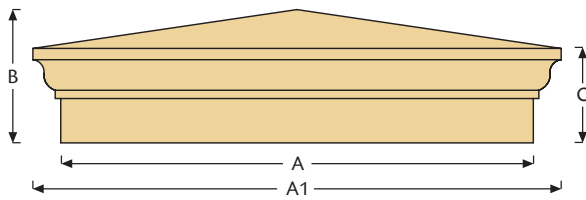
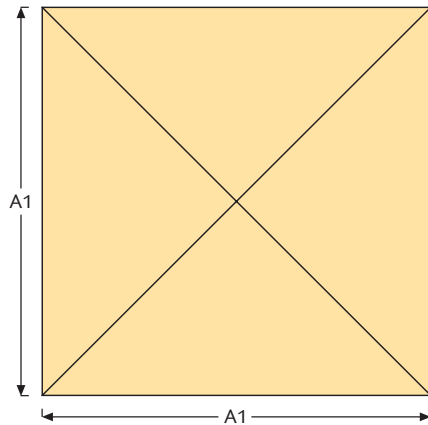

Type	A	A1	B	C
APC8	850	950	240	170

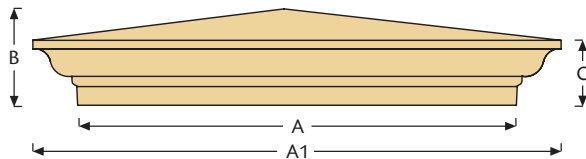

Type	A	A1	B	C
APC9	890	1010	175	125
APC10	910	1100	200	135



BALL FINIAL

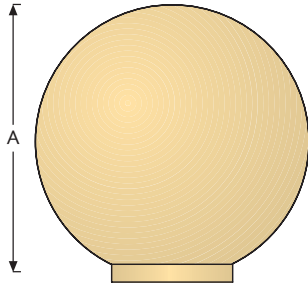

Type	A
BF1	225 diameter
BF2	305 diameter
BF3	380 diameter
BF4	450 diameter
BF5	610 diameter

BALL FINIAL AND BASE NECK

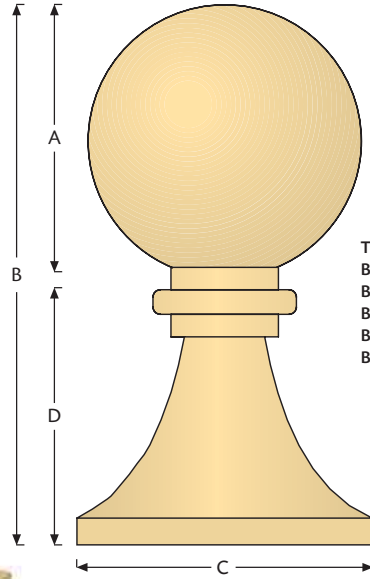

Type	A	B	C	D
BFBN1	225	390	225	165
BFBN2	305	615	330	310
BFBN3	380	780	380	400
BFBN4	450	886	450	436
BFBN5	610	1230	660	620

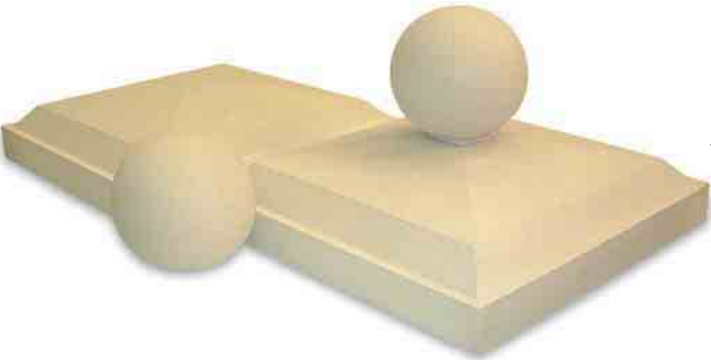

The apex of the Architectural Pier Cap can be supplied flat to accommodate Ball Finial or Ball Finial with Base Neck.

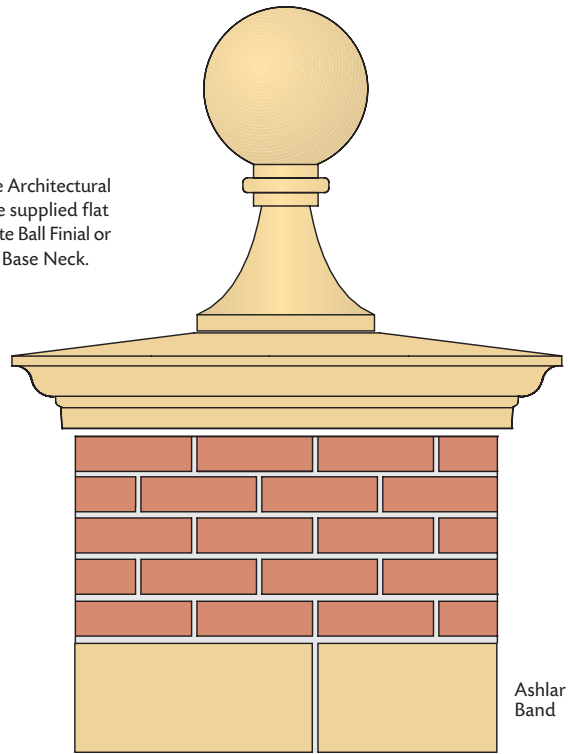
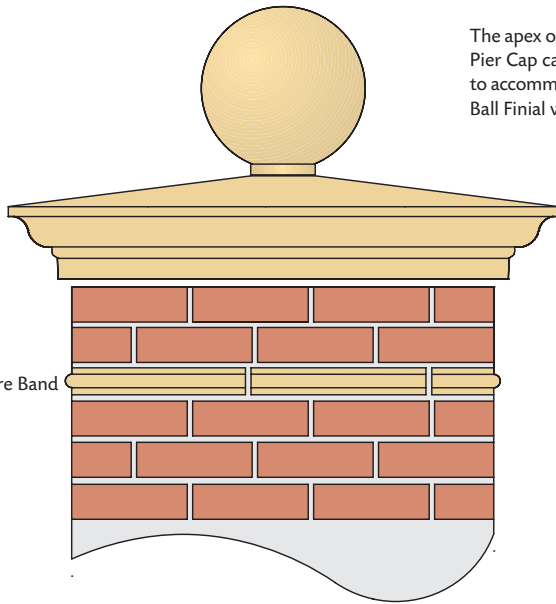

PIER FEATURE BAND

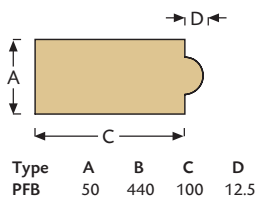

Type	A	B	C	D
PFB	50	440	100	12.5

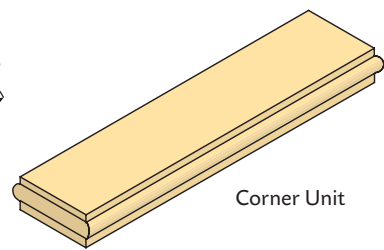
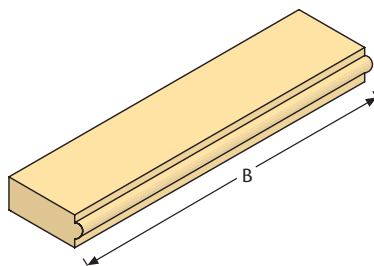

Columns

TUSCAN COLUMNS

Type	A	B	C	D
Col 210/150	310	210	150	2165
Col 218/185	294	218	185	2000
Col 260/220	360	260	220	2420
Col 310/270	434	310	270	2940
Col 400/280	600	400	280	3515
Col 400/340	600	400	340	3515
Col 500/430	710	500	430	5197
Col 600/500	800	600	500	6090

Note: Where half columns are required as pilasters please specify e.g. Pilaster 218/185

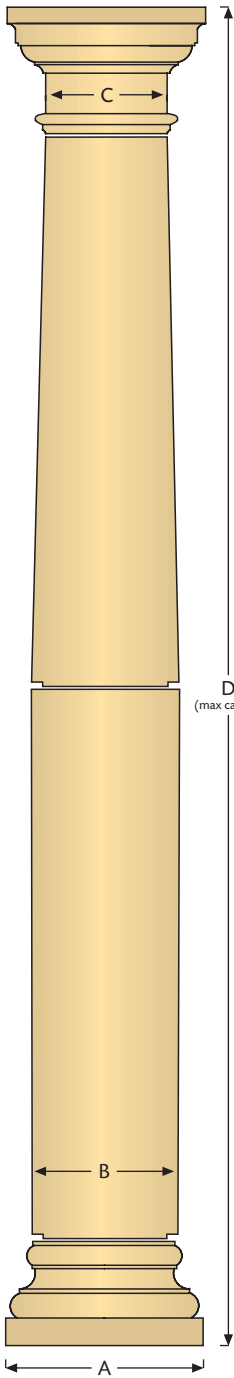

Pedestals to suit columns.

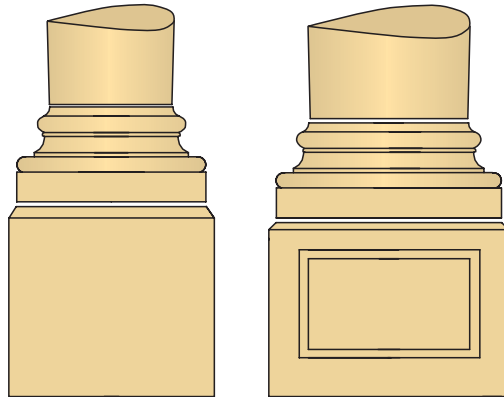

Chamfer Pedestal

Panel Pedestal

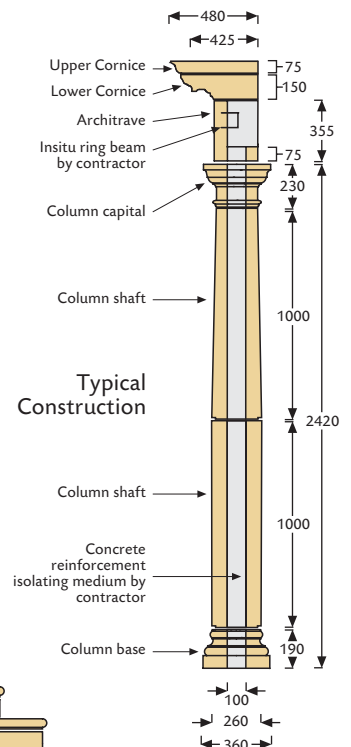
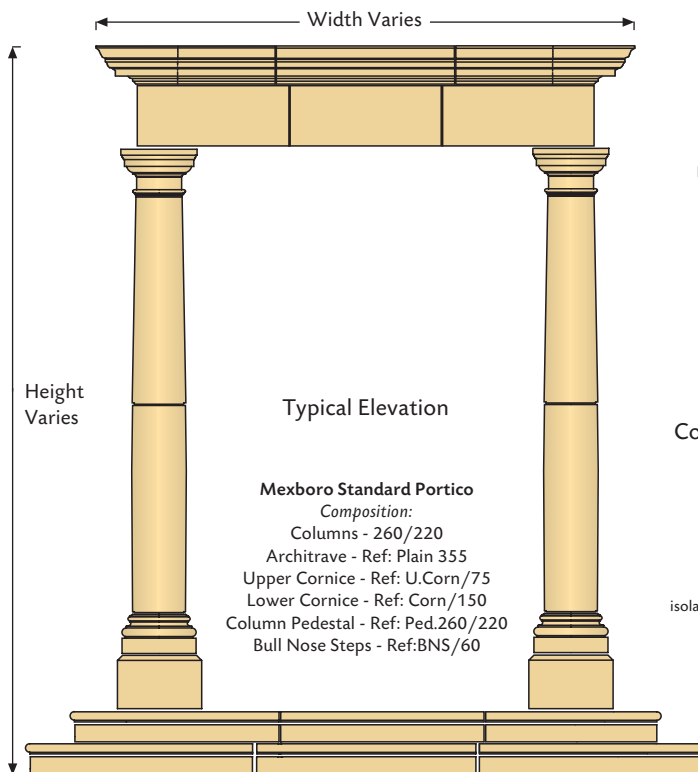

ARCHITRAVE

ARCH/PLAIN (Plain)

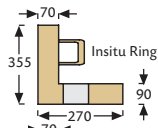

ARCH/NIB (With nib)

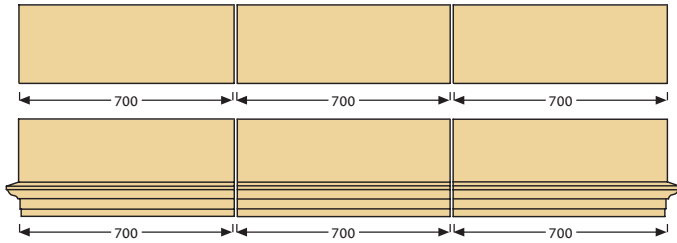
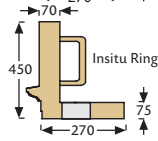

UPPER CORNICE

U.CORN/75

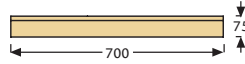

Section

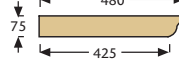

Right Hand Return Elevation



CORNICE

CORN/170

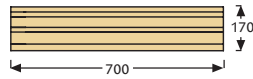

Section

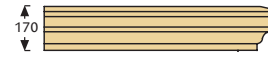

CORN/250

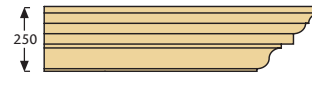
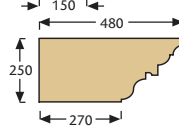
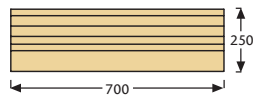

CORN/220

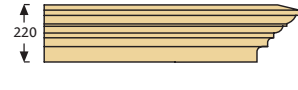
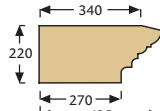
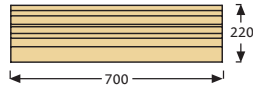

CORN/DW/150

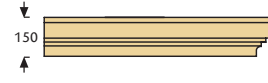
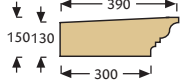
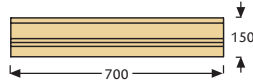

CORN/150

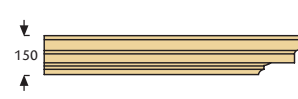
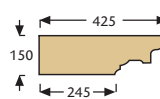
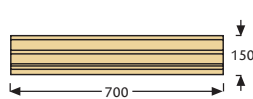

DENTIL COURSE

DEN/90

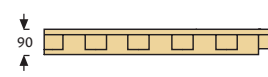
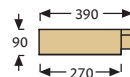
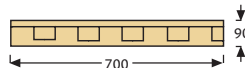

PORTICOS Typical elevations using standard Architrave, Cornice and Dentil components.

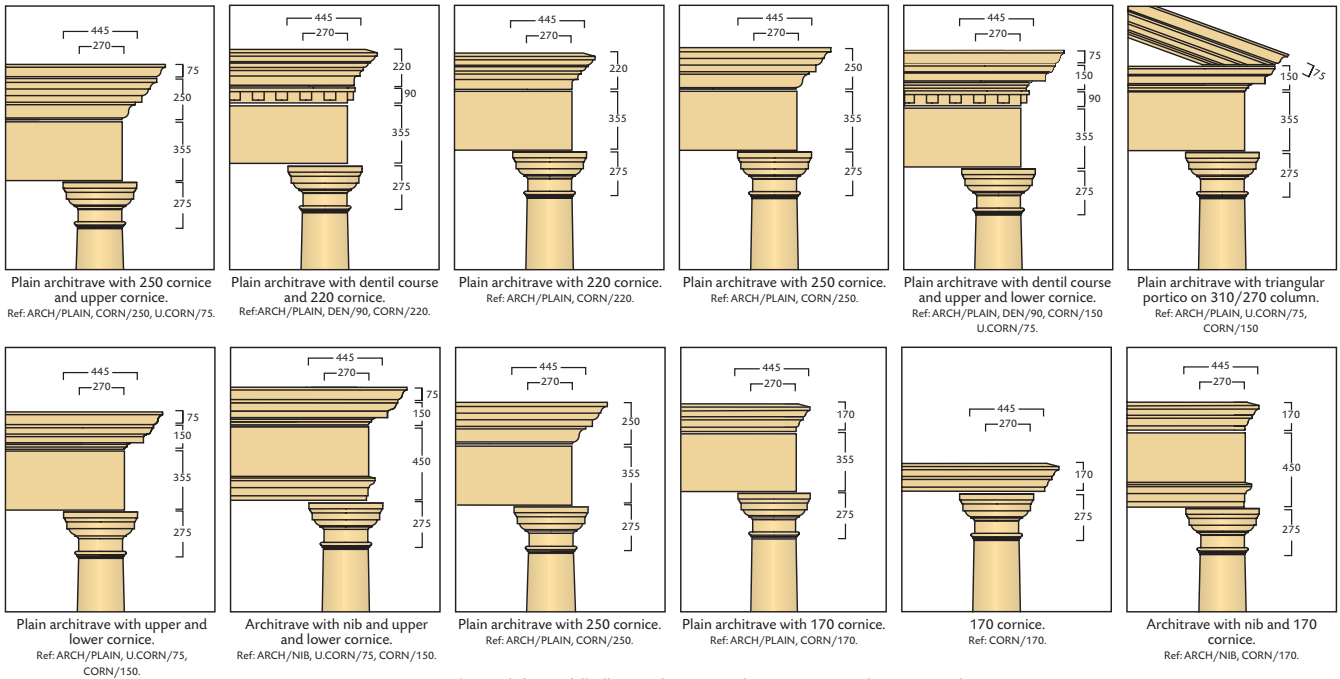

Please ask for our fully illustrated 10 page Columns - Cornice and Porticos Brochure.

Sectional Column Cladding Units

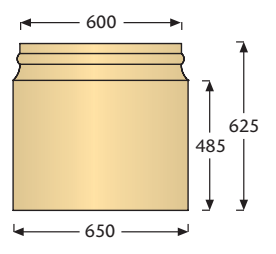
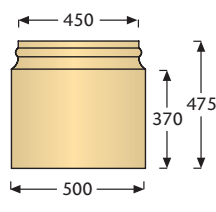
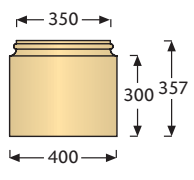
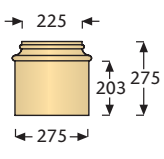
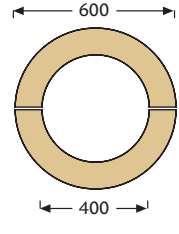
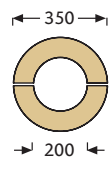
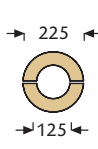
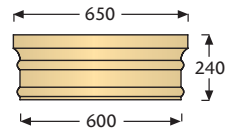
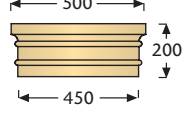
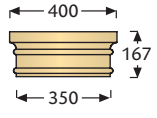
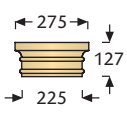

SCCU 1

SCCU 2

SCCU 3

SCCU 4

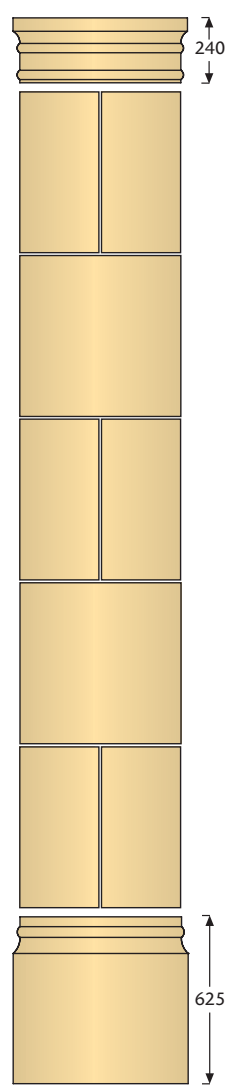
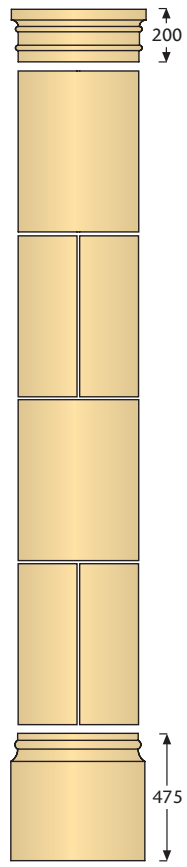
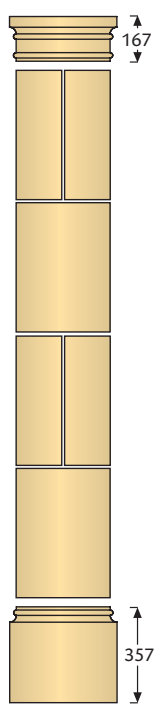
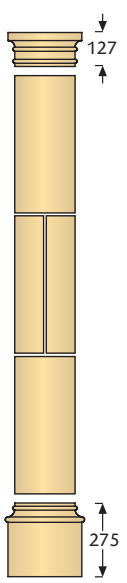

REBATED GATE PIER GP1

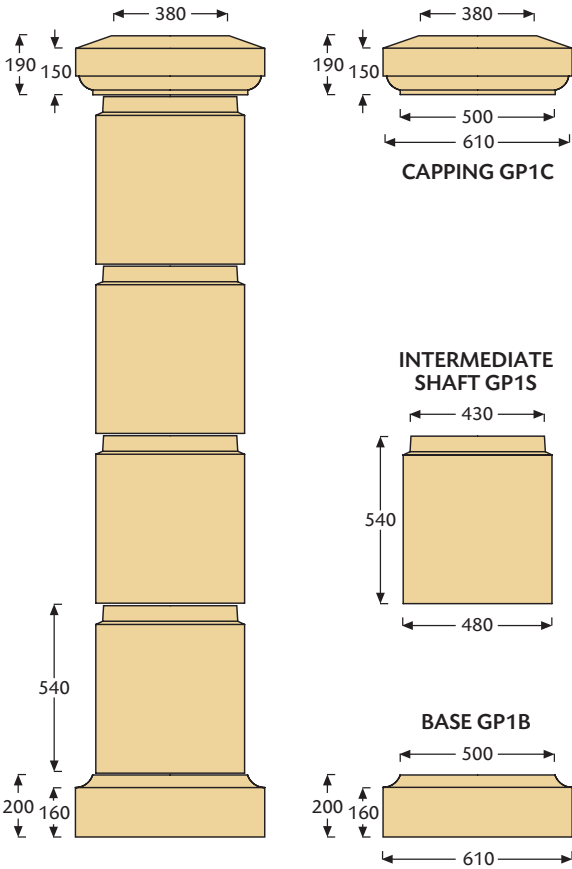

PANEL GATE PIER GP2

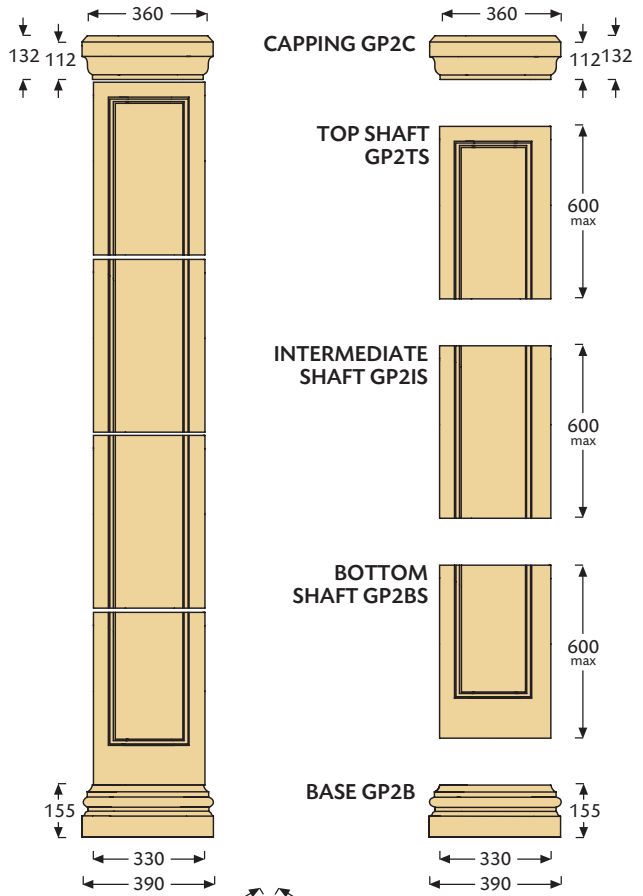

CORBELS

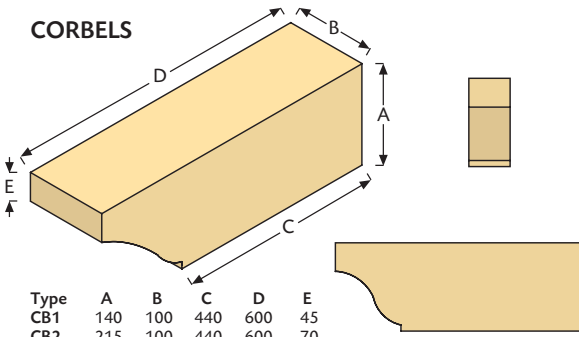

Type	A	B	C	D	E
CB1	140	100	440	600	45
CB2	215	100	440	600	70
CB3	140	150	440	600	45
CB4	215	150	440	600	70
CB5	140	215	440	600	45
CB6	215	215	440	600	70

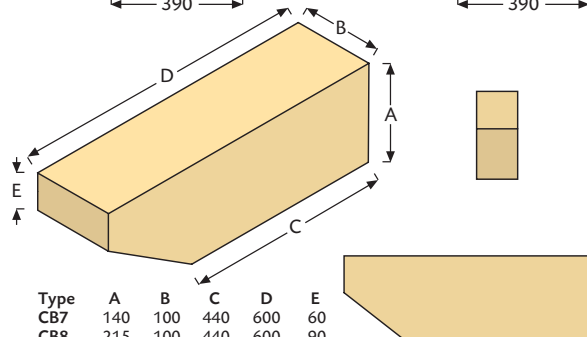

Type	A	B	C	D	E
CB7	140	100	440	600	60
CB8	215	100	440	600	90
CB9	140	150	440	600	60
CB10	215	150	440	600	90
CB11	140	215	440	600	60
CB12	215	215	440	600	90

GABLE VENTS

GBLVNT1

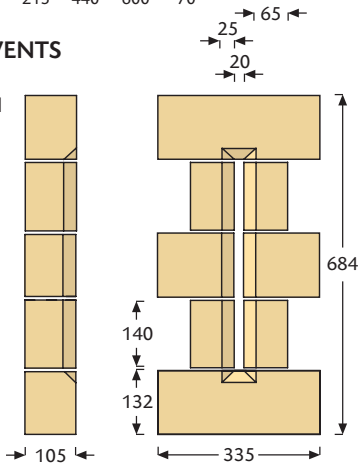

GBLVNT2

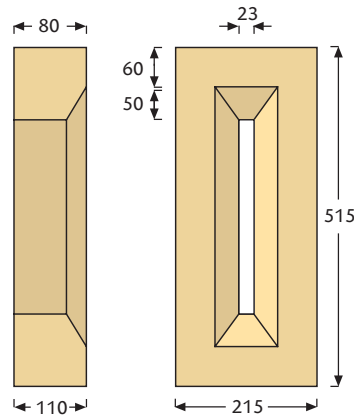

GBLVNT2 supplied in 2 number sections 800mm max overall.

Balustrading

'The Complete Range of Balusters'.

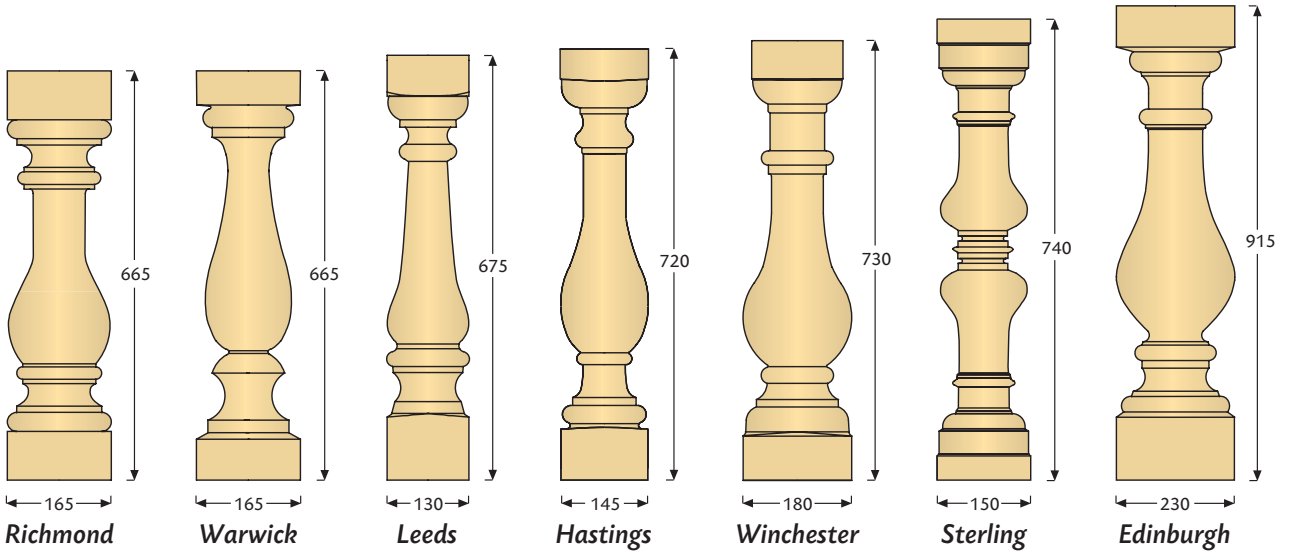
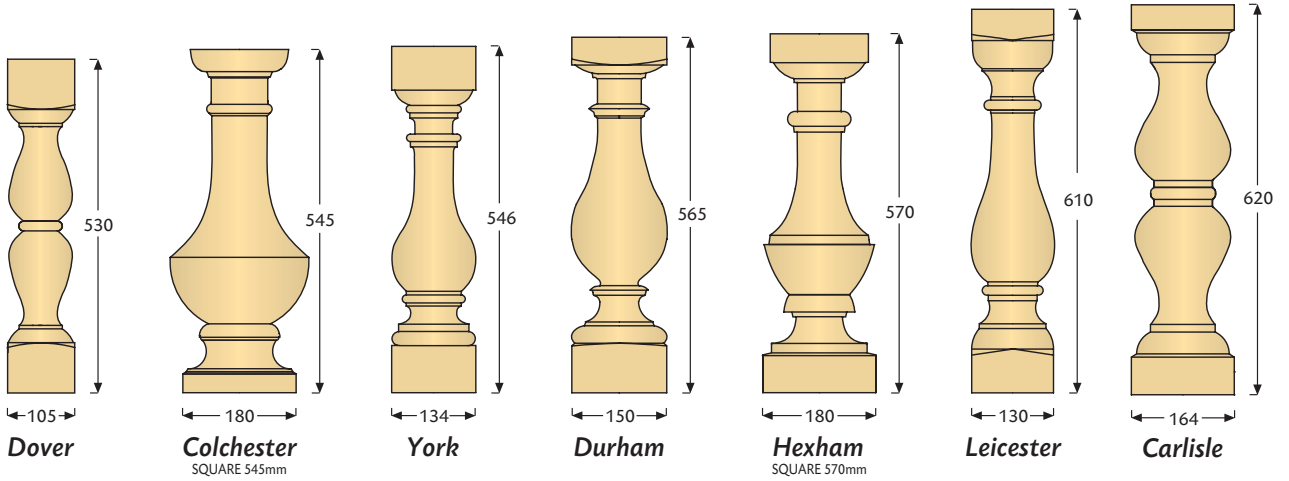
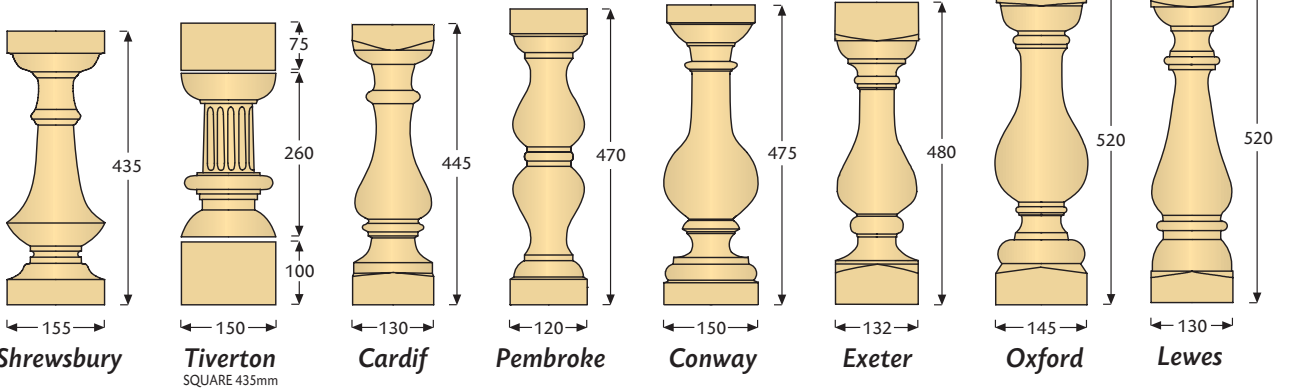

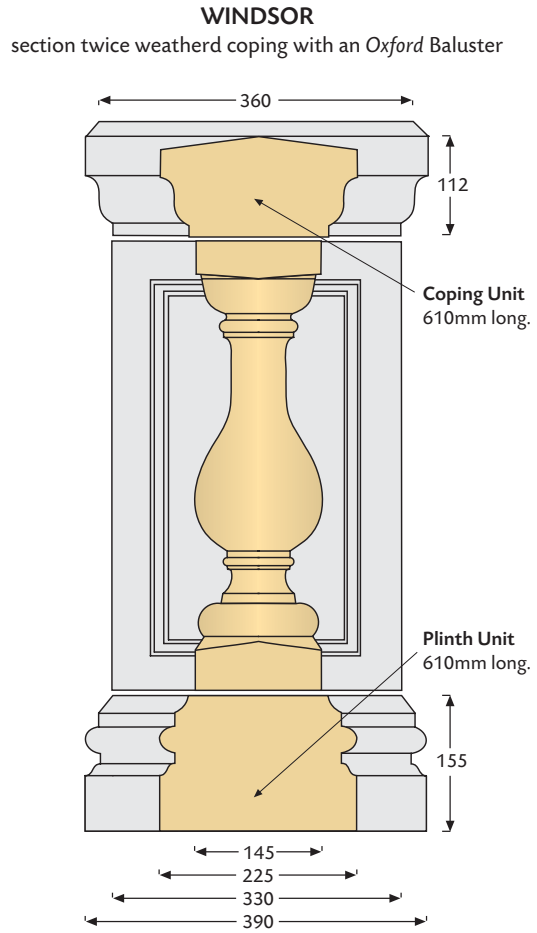
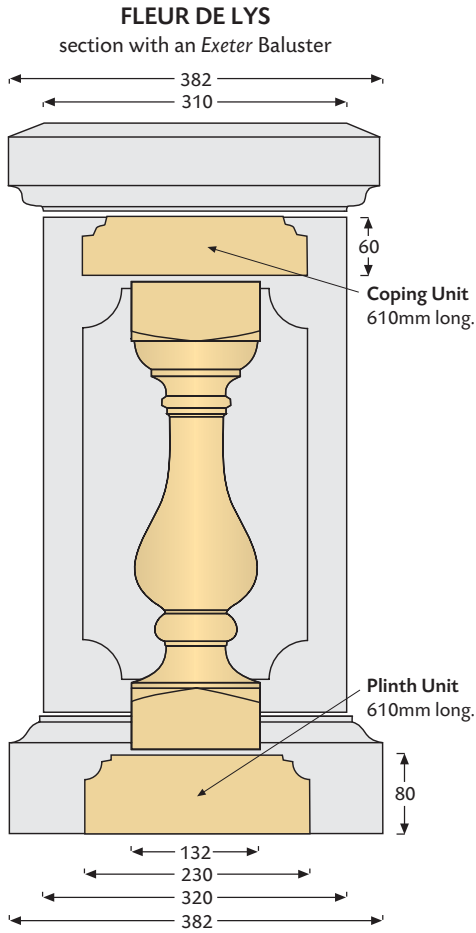

SANDRINGHAM
section flat top coping with a *Carlisle* Baluster

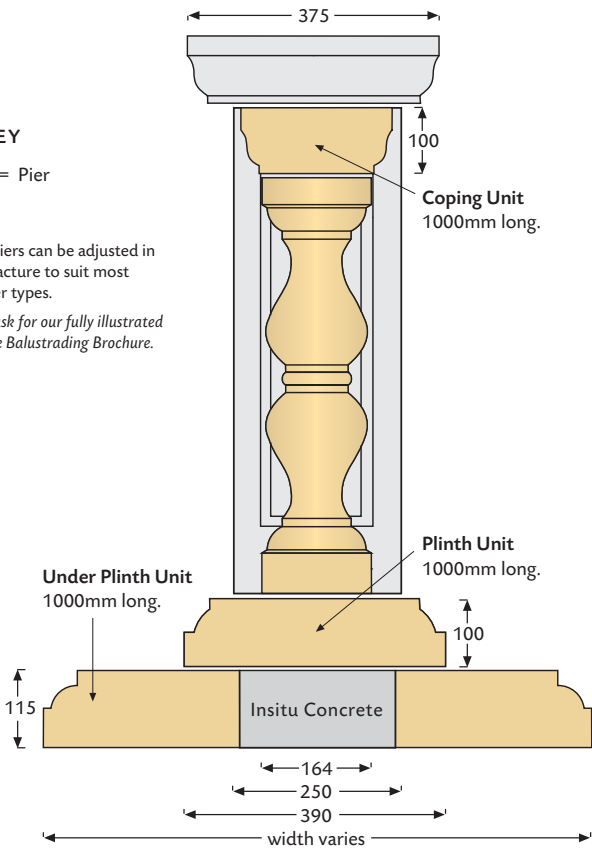

HERITAGE
section twice weathered coping with a *Richmond* Baluster

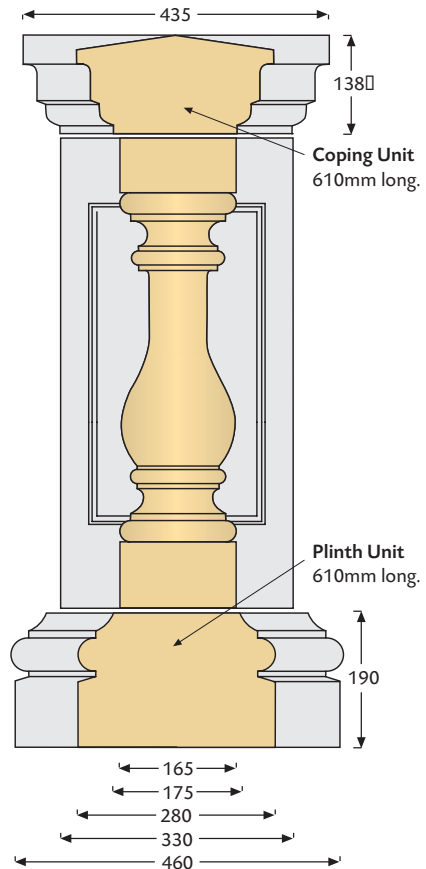

Piers

VICTORIAN PIER
Ref: VP

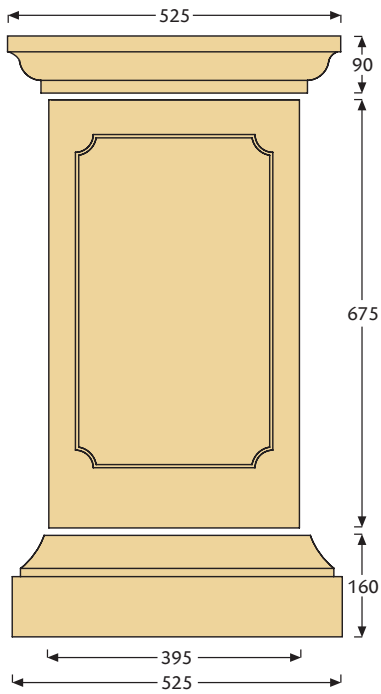

SANDRINGHAM PIER
Ref: SP

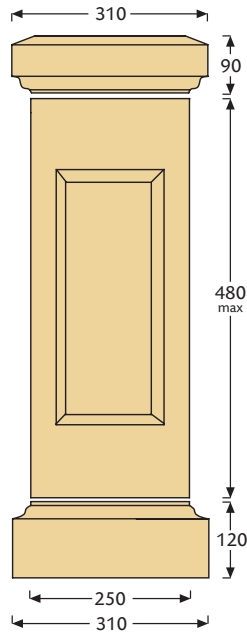

HERITAGE PIER
Ref: HP

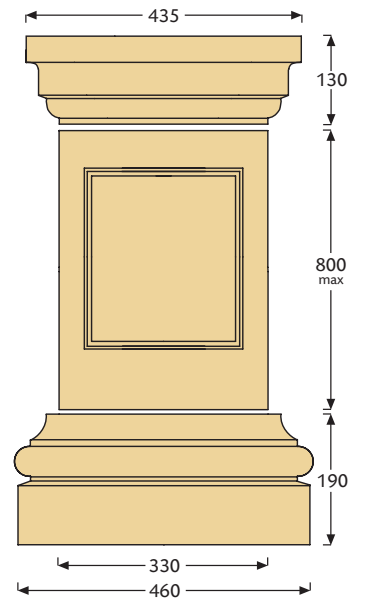

WINDSOR PIER
Ref: WP

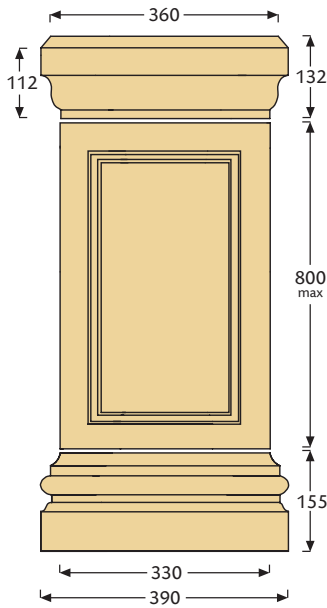

FLEUR DE LYS PIER
Ref: FLDLYSP

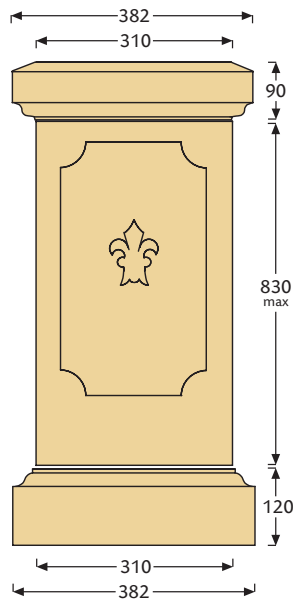

SQUARE PORCH PIER BLOCK PPB1

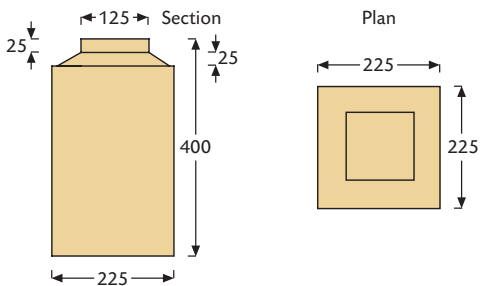

POOL / PLANTER SURROUND Ref: PLSRND

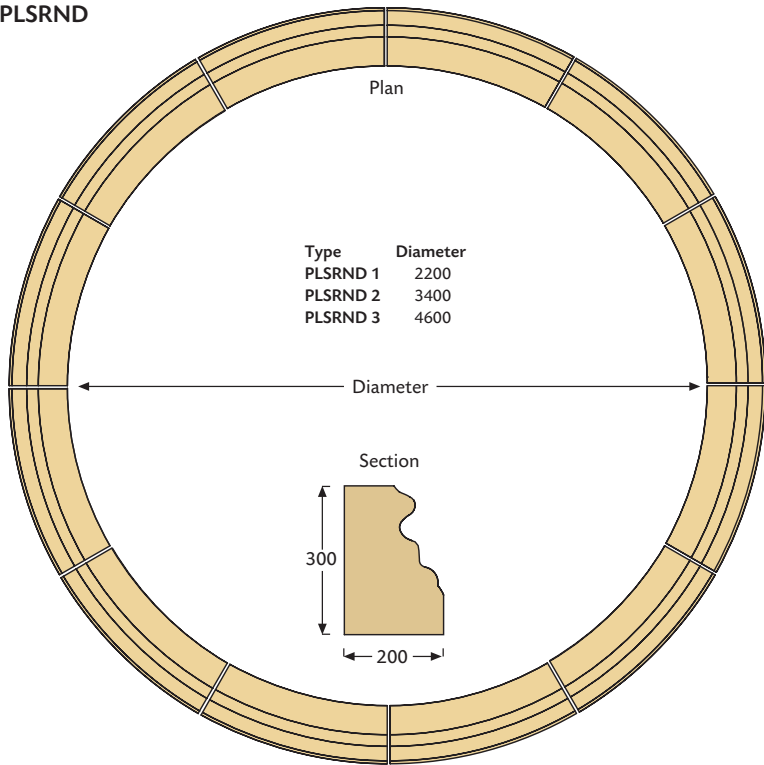

SWIMMING POOL COPING SPC1

Internal Corner Plan

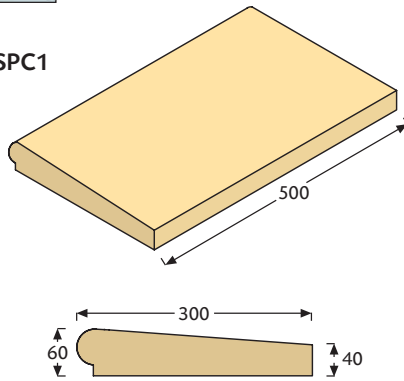
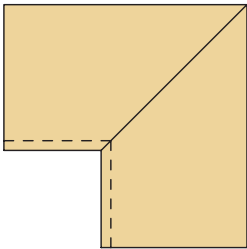

DATE STONES

Plain Date Stone

Type	A	B	C
PDS1	140	440	100
PDS2	215	440	100
PDS3	290	440	100

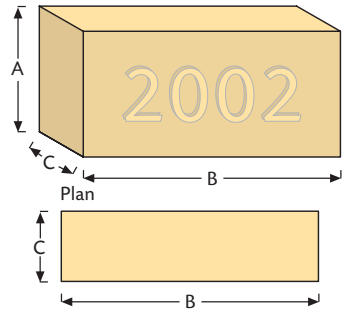

Victorian Urn and Pier

CLASSIC URNS

Type	Height	Width	Base
Victorian Urn	780mm	690mm	350mm
Victorian Pier	920mm	525mm	525mm
Regency Urn	460mm	550mm	260mm
Heritage Pier Base	190mm	365(top)	460mm
Tudor Urn (large)	430mm	510mm	295mm
Tudor Urn (small)	335mm	380mm	215mm



Tudor Urn



Regency Urn and Heritage Pier Base

Chamfered Date Stone

Type	A	B	C	E
CDS1	140	440	100	25
CDS2	215	440	100	25
CDS3	290	440	100	25

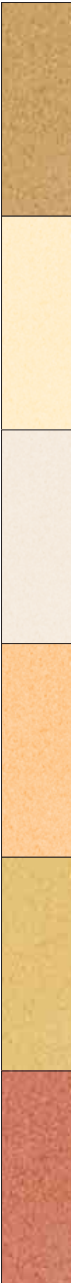
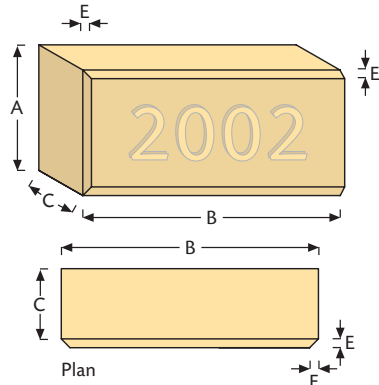

THE ELM

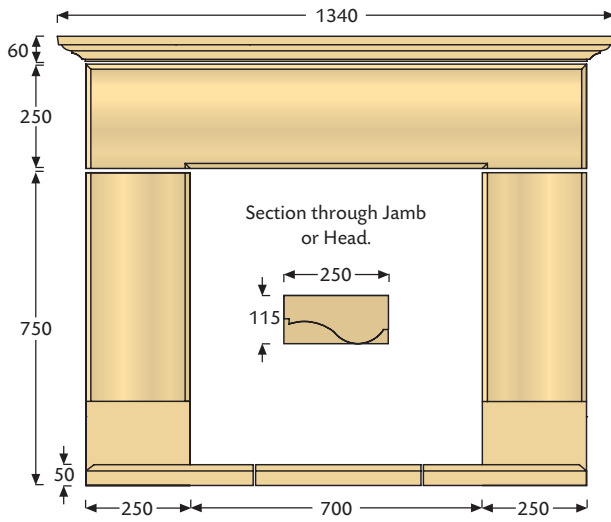

THE ALDER

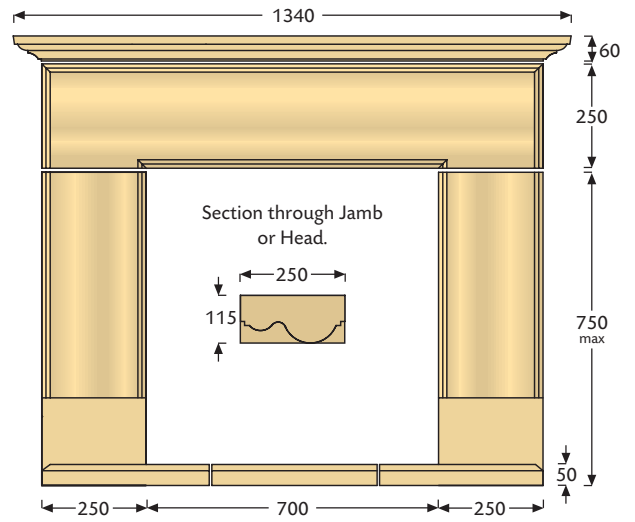

THE WILLOW

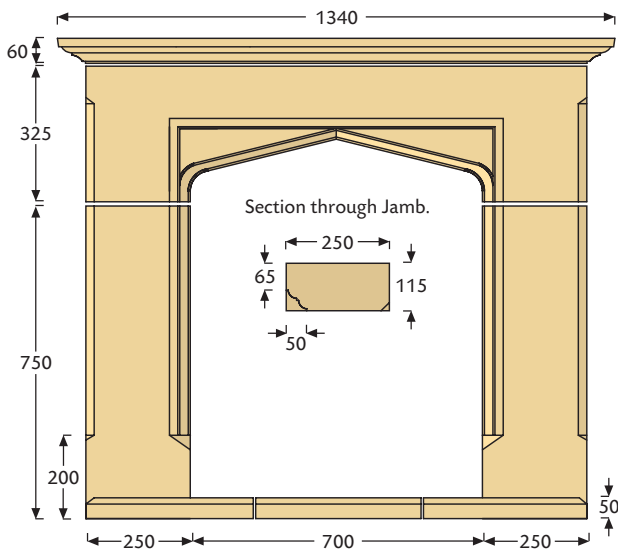

THE HAZEL

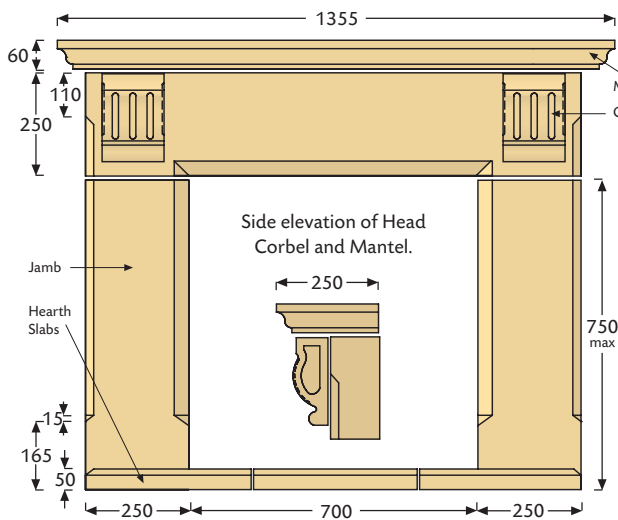

THE OAK

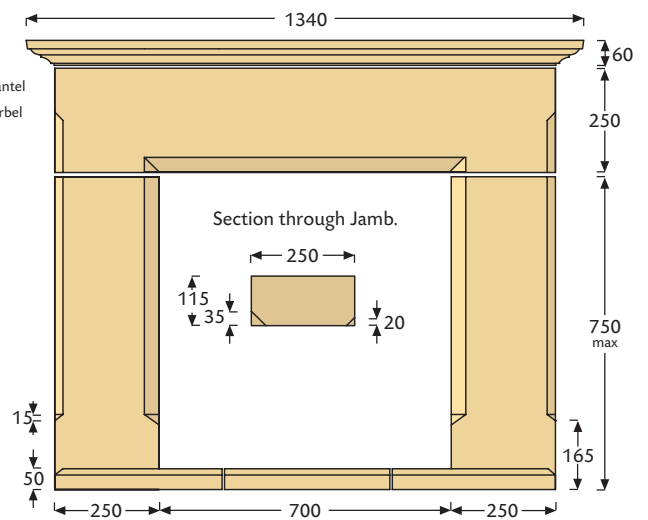

BULL NOSED TREADS

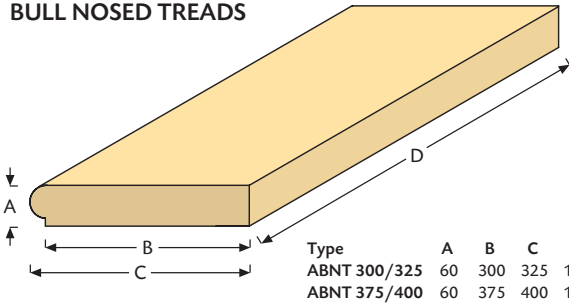

Returned left and right hand returns available.

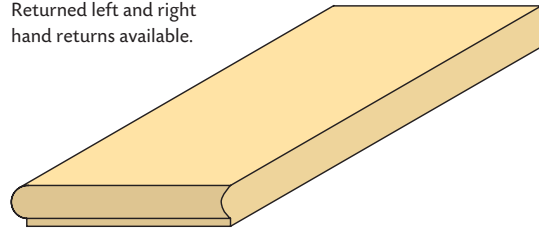

Type	A	B	C	D
ABNT 300/325	60	300	325	1500 max
ABNT 375/400	60	375	400	1500 max

PLAIN TREADS

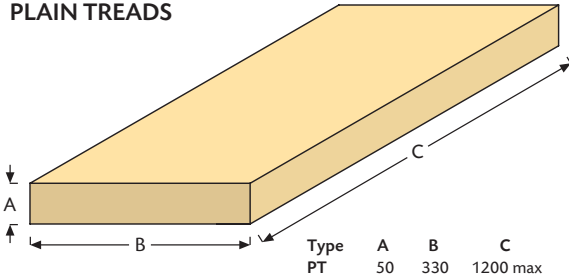

Type	A	B	C
PT	50	330	1200 max

RISERS

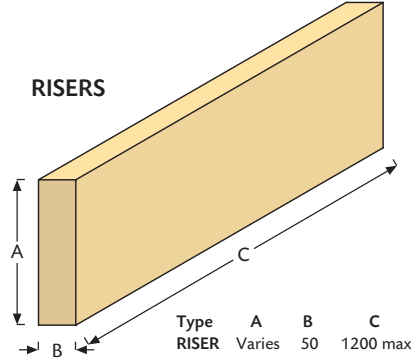

Type	A	B	C
RISER	Varies	50	1200 max

ARCHITECTURAL BULL NOSED L STEPS

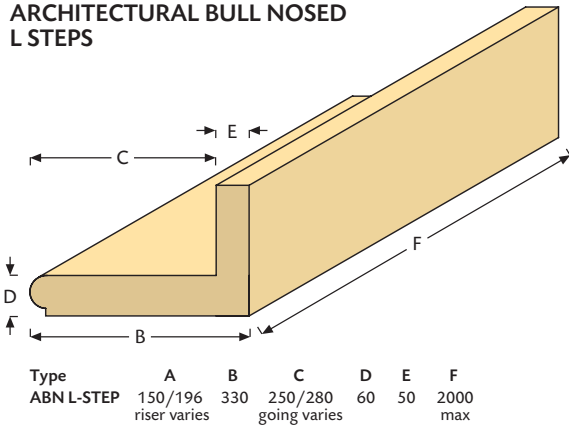

Type	A	B	C	D	E	F
ABN L-STEP	150/196 riser varies	330	250/280 going varies	60	50	2000 max

PLAIN L STEPS

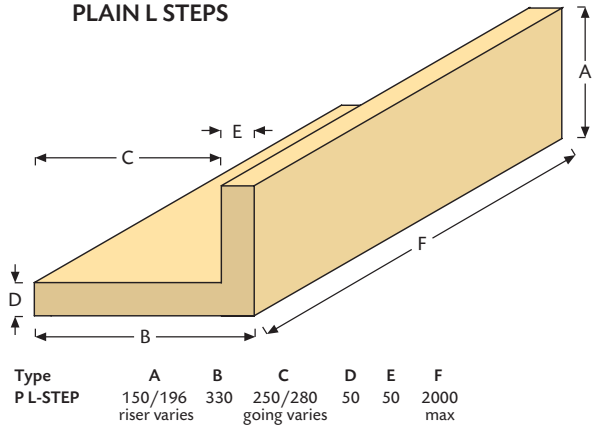

Type	A	B	C	D	E	F
PL-STEP	150/196 riser varies	330	250/280 going varies	50	50	2000 max

All the above are manufactured at standard lengths - details on request.



DOOR THRESHOLDS

Type	A	B	C	D	E
DT1	150	65	45	1500	100
DT2	150	140	120	2100	100

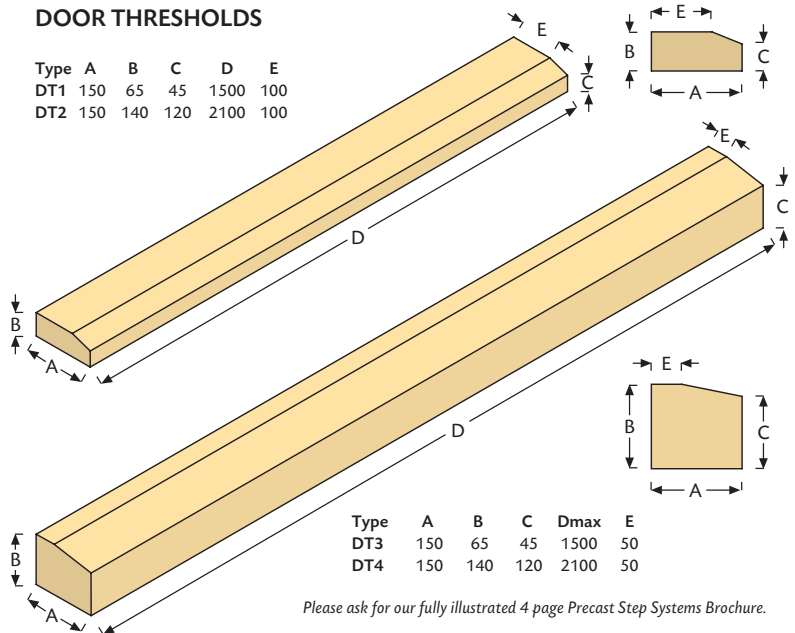

Type	A	B	C	Dmax	E
DT3	150	65	45	1500	50
DT4	150	140	120	2100	50

Please ask for our fully illustrated 4 page Precast Step Systems Brochure.





Talk to us about your projects and requirements.

Our technical and sales team will be happy to visit sites, supply quotations, and give structural and technical advice.

Other Products.

For further information or brochures on any of the following products please contact us or visit our website: www.mexboroconcrete.co.uk

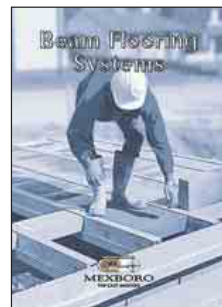
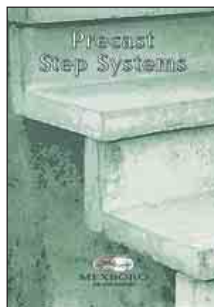
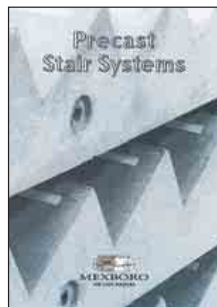

Structural

- Beam & Block Flooring • Lintels • Staircases & Landings • Step & Riser Units • Ground Beams • Duct Covers • Retaining Walls • Frames, Columns & Beams • Bollards • Polished Face Units • Specialist Work

Architectural

- Urns • Ball Finials • Coping & Pier Caps • Columns • Porticos • Door Surrounds • Quoin Stones • Window Cills & Surrounds • Gate Piers • Lintels & Gable Vents • Fireplace Surrounds • Plinth/String Courses • Faced 'Ashlar' Blockwork

For over thirty years Mexboro has specialized in the manufacture of high quality architectural cast stone and structural precast concrete and it is now one of the largest precast specialists in the South West of England.

Our portfolio of products spans the building industry from quality architectural stonework to precision structural concrete, and from individually designed one-off units to an extensive range of standard lines.

Mexboro is proud to have been associated with the supply of cast stone to numerous prestigious developments including projects for English Heritage, The National Trust, P.S.A. and the Ministry of Defence.



MEXBORO CONCRETE LIMITED

'Manufacturers of Architectural & Structural Precast Concrete'
Yalberton Industrial Estate • Alders Way • Paignton
Devon • TQ4 7QQ

Telephone: 01803 558025 • Facsimile: 01803 524717

Email: sales@mexboroconcrete.com

Web: www.mexboroconcrete.com

We strongly recommend that when using our products in any application professional advice is sought to confirm compliance with building regulations. The Company's continual development of new products means that the information in this brochure is subject to change without prior notification. Colours shown are only for illustration due to the printing process involved.